

INSTALLING TELEVISION IN THE HOME

Television

and SHORT-WAVE WORLD

1/-

MONTHLY

DECEMBER, 1936

No. 106. Vol. ix.

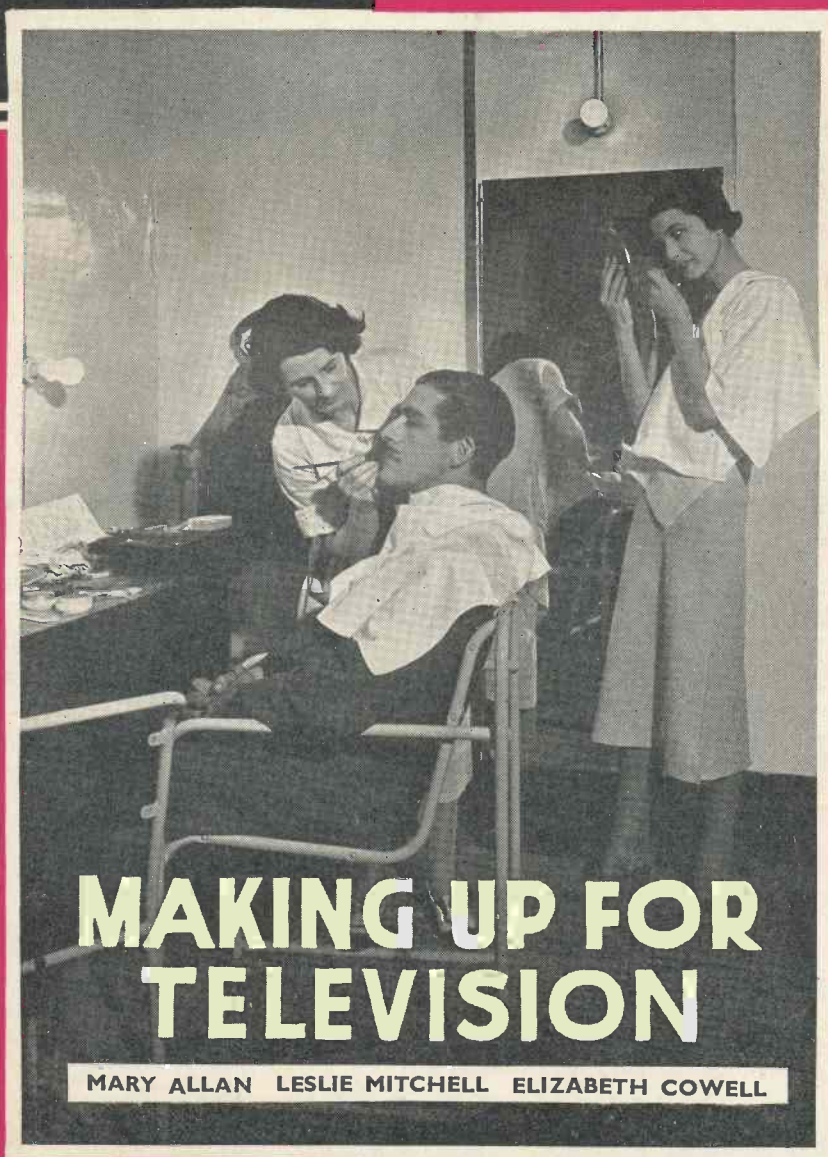

**MAKING UP FOR
TELEVISION**

MARY ALLAN LESLIE MITCHELL ELIZABETH COWELL

**TELEVISION
RECEIVER**

for you to

BUILD

**AMATEUR-BANDS
SUPER-HET "7"**

FULL DETAILS

BERNARD JONES PUBLICATIONS LTD.
CHANSITOR HOUSE, CHANCERY LANE
LONDON W.C.2.

THE FIRST TELEVISION JOURNAL IN THE WORLD

Mullard

CATHODE RAY TUBES

Mullard have held for years a unique position as pioneers in the Radio industry. Mullard Master Valve reputation is upheld in the new field of Television by the Mullard Cathode Ray Tubes.



TYPE E46-12 FOR TELEVISION

Double Electrostatic Deflection

Sensitivity $\frac{650}{v}$

Maximum Anode Volts 6,000 v.

Screen 12", White.

PRICE 15 GNS.

A full list of Mullard Cathode Ray Tubes for Television and other purposes will be supplied upon application and we invite trade enquiries and queries.

Mullard Wireless Service Co., Ltd., Mullard House, 225, Tottenham Court Road, London, W.1

CVS-57

TELEVISION

and SHORT-WAVE WORLD

Special Features

	PAGE
The Farnsworth Television Receiver ...	676
The Opening of Britain's First Television Service ...	677
Philco (U.S.A.) Television ...	680
Television in the Home ...	681
How to Operate the Cathode-ray Tube ...	683
Electron Multiplier Research ...	686
A New Photo-electric Element ...	692
Buyers Guide to Television Receivers	693
"Television's" Guaranteed Receiver	697
Recent Television Developments ...	709
The Amateur Bands Super-het 7 ...	711
Folded Duoblet Aerial ...	716
New Transmitting and Receiving Aerial System ...	718
Beginner's Transmitter ...	721
Transmitting for the Beginner ...	722
Pre-selector for Commercial Receivers ...	728
German Short-wave Transmitters ...	732
Building an Output Meter ...	734

COMMENT OF THE MONTH

The Programmes

AT this early stage it would be manifestly unfair unduly to criticise the programmes transmitted from Alexandra Palace, but we are only voicing a general opinion when we say that they do not come up to a standard which the degree of technical development warrants. It is realised that there will be a great deal to learn as regards presentation, and viewers are fully aware of this. Our chief grumble, however, concerns the cheese-paring policy that appears to have been adopted. On many occasions there have been intervals totalling over fifteen minutes in a brief hour's programme. It should be appreciated that owners of television receivers are not disposed to run a matter of twenty valves plus the cathode-ray tube merely to hear a few gramophone records; neither are they pleased to have to sit and look at the hands of a clock. If intervals are really necessary then it should be possible to make them more entertaining, or at least more informative.

Our second great grumble concerns the repetition of material that is presented. Particularly is this the case with films. Everybody has seen the film "Television Comes to London" so many times that the point of boredom has long been passed. We have also been satiated with the feature films which appear to crop up in practically every programme. These films are not topical and if repetition is necessary on the score of economy, then surely a greater variety should be available, which could be repeated at less frequent intervals. Repetition also appears to be creeping in in the case of artists. Repeat performances, unless they are given on the same day at different times, should not be necessary within such a brief period as a couple of weeks or so.

Timing appears to be a very haphazard business: rarely have the advertised features started to time and the result has been a considerable amount of general uncertainty if one wished to see some particular feature.

Another point is the apparent laxity of studio routine. Frequently, shadows of persons passing between some of the lights and the subject are visible, and on one occasion there appeared out-of-focus images of two persons in the background who were not in any way concerned with the subject. More contrast between the dress of artists and the studio background would be desirable: several presentations have suffered on this account, but in fairness we must say that more attention appears to have been given to the matter in the more recent transmissions.

TELEVISION AND SHORT-WAVE WORLD

Proprietors:

BERNARD JONES PUBLICATIONS, LTD.

Editor-in-Chief:

BERNARD E. JONES.

Editor:

H. CORBISHLEY.

Editorial, Advertising and Publishing Offices:

Chansitor House, 38, Chancery Lane, London, W.C.2.

Telephones: Holborn 6158, 6159

Telegrams: Beejapee, Holb., London.

Subscription Rates: Post paid to any part of the world—3 months, 3/6; 6 months, 6/9; 12 months 13/6.

Published Monthly—1/- net. (Last Wednesday in every month for following month).

Contributions are invited and will be promptly considered. Correspondence should be addressed according to its nature, to the Editor, the Advertisement Manager, or the Publisher, "Television and Short-wave World," Chansitor House, Chancery Lane, London, W.C.2.

IMPORTANT

"Television and Short-wave World" is registered at the General Post Office, London, for transmission to Canada and Newfoundland by Magazine Post. Entered as Second-class mail matter, Boston, Mass.

THE FARNSWORTH TELEVISION RECEIVER

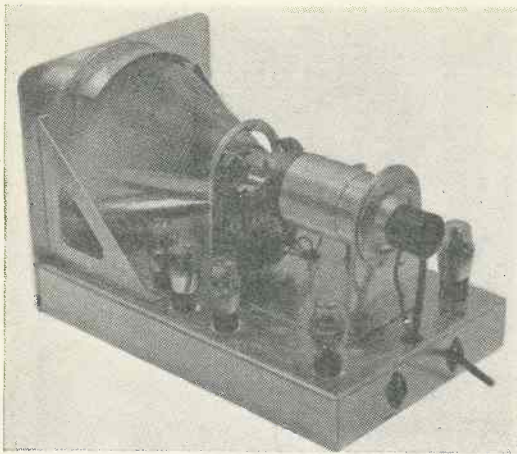

We are indebted to "Radio Engineering" (New York) for this description of the Farnsworth television receiver. An interesting feature is that acorn valves are used.

The cathode-ray tube showing the magnetic deflection coils. This unit is mounted in the top compartment of the cabinet.

ALTHOUGH development work is still in progress, Farnsworth Television, Inc., has felt justified in releasing the preliminary details of their television receiver. The circuit diagram is given here.

At first glance, the receiver circuits appear to be more or less conventional. In any event, the sound channel may be considered entirely so, except, as in the case of the vision channel, for the high intermediate frequency employed. The use of "acorn" valves in the sound channel is likewise unconventional.

It is apparent from the diagram

that the same oscillator functions to supply two intermediate frequencies—one, at 11.25 mc., for sound and the other, at 13.25 mc., for picture. Presumably, the requisite bandwidth for reasonably high audio quality can be obtained by the usual tuned-circuit i-f transformers, without the use of band-widening resistances such as will be seen shunted across the vision i-f transformers.

Crystal filters for intermediate frequencies as high as 13.25 mc. are not entirely feasible at the present state of the art, although the beautifully sharp cut-off of these filters, along

with their nearly square response characteristics, should offer an ideal solution to this problem if they could be built to function at these high frequencies—but more research work is necessary. Resonant line filters may have the same possibilities as i-f coupling elements.

It is of interest to note the high degree of smoothing necessary for the video circuit H.T. supply. While figures are not available, it is probably reasonable to assume that the three-section power supply filter gives an attenuation in excess of 70 db. to frequencies of 120 cycles and above.

The receiver is built on three chassis. At the top is the Oscillight unit, shown by the photograph.

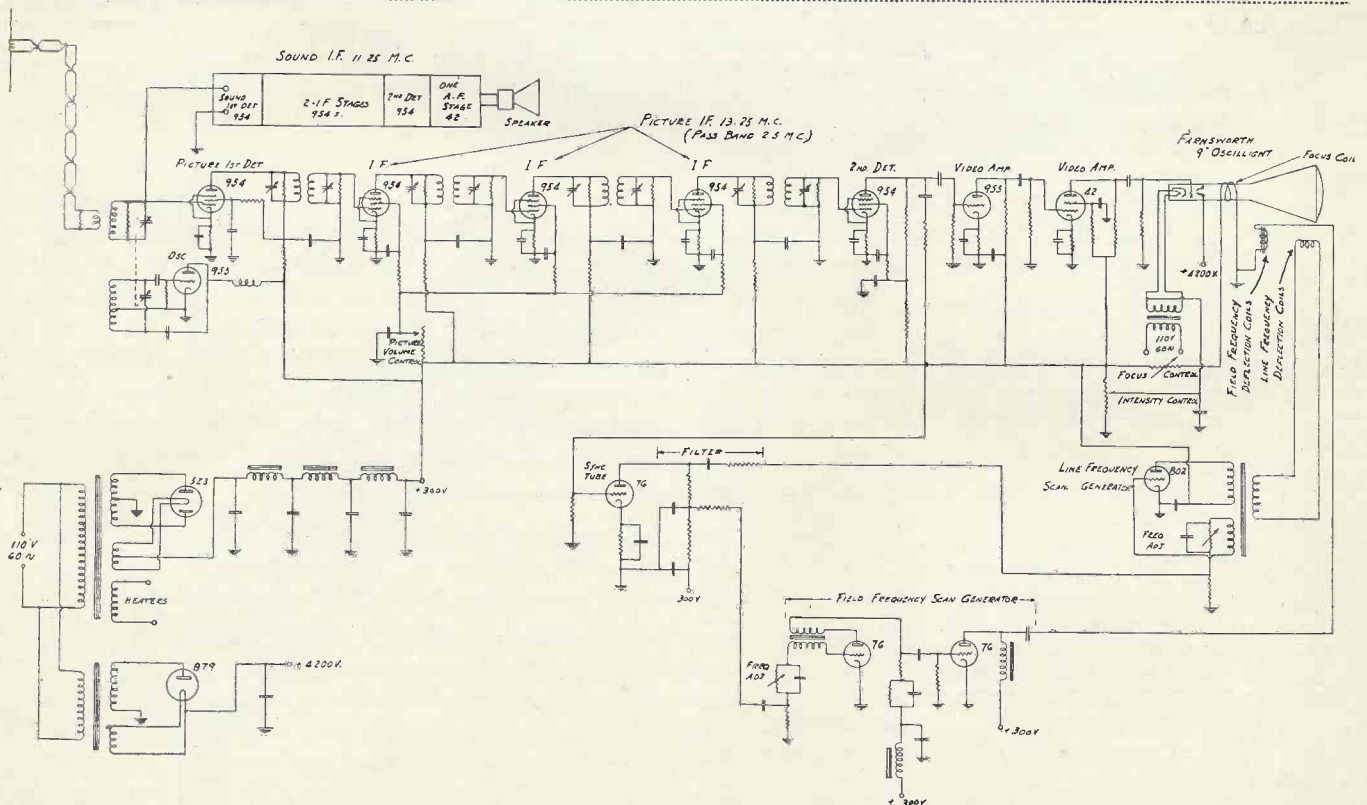

The circuit diagram of the Farnsworth vision and sound receiver. It is interesting to note that in the vision section acorn-type pentode valves are used in the first detector, three I.F. amplifying, and second detector stages. Acorn triodes are used in the oscillator and first low-frequency stages. The output valve is a conventional L.F. pentode. The 5-valve sound receiver, built on similar lines to the vision receiver, uses acorn valves in the first four stages with a small pentode in the final speech amplifier.



THE OPENING OF BRITAIN'S FIRST TELEVISION SERVICE

Britain's first television station was officially opened on Monday, November 2, at 3 p.m., and the service was inaugurated by the Postmaster-General, Major The Right Honourable G. C. Tryon. Speeches were delivered during the proceedings by the Chairman of the B.B.C. (Mr. R. C. Norman), the Postmaster-General (Major G. C. Tryon) and the Chairman of the Television Advisory Committee (Lord Selsdon).

THE opening ceremony was repeated, being first televised by the Baird system and later by the Marconi-E.M.I. system, a brief entertainment programme being interpolated between the two official opening ceremonies.

The Postmaster-General was introduced to the public by Mr. R. C. Norman who in the course of a brief speech said:—"We are met, some in this studio at the Alexandra Palace and others at viewing points miles away, to inaugurate the British Television Service. My first duty is to welcome you, Major Tryon, in the name of the British Broadcasting Corporation, and to say how happy we are that you should have done us the honour of performing the inaugural ceremony.

"We of the B.B.C. are proud that the Government should have decided to entrust us with the conduct of the new service. We are very conscious of the responsibilities which that decision imposes upon us. At this moment of the starting of television our first tribute must be to those whose brilliant and devoted research, whose gifts of design and craftsmanship have made television possible. We are honoured by the presence of some of them here to-day. We wish also to record, Lord Selsdon, the guidance and encouragement which we have received from the two Television Committees over which you have presided. As for the future, we know already that television is much more complicated than sound broadcasting. We are, however, confident that television, in its special combination of science and the arts, holds the promise of

unique, if still largely unchartered, opportunities of benefit and delight to the community.

"We are happy to think that some of its earliest opportunities will have as their setting the historic pageantry of next summer.

"The foresight which secured to this country a national system of broadcasting promises to secure for it also a flying start in the practice of television.

"At this moment the British Television Service is undoubtedly ahead of the rest of the world. Long may that lead be held. You may be assured that the B.B.C. will be resolute to maintain it.

"To-day's ceremony is a very simple programme. In every respect it will doubtless seem primitive a few years hence to those who are able to recall it. But we believe that these proceedings, for all their simplicity, will be remembered in the future as an historic occasion, not less momentous and not less rich in promise than the day, almost exactly fourteen years ago, when the British Broadcasting Company, as it then was, transmitted its first programme from Marconi House. In that belief, Mr. Postmaster-General, we asked you to take the leading part in this ceremony, and I now invite you to inaugurate the new service."

The Postmaster-General

Major Tryon said:—

"Lord Selsdon, Mr. Norman and all who are watching this ceremony from afar.

"It is a great privilege to be invited to inaugurate

PLANS FOR MORE STATIONS

the British Television Service. For we are launching to-day a venture that has a great future before it. For me, it is also a new and extremely interesting experience. Though I have had experience of speaking into the microphone many times, this is the first occasion on which I have faced the television camera.

"Few people would have dared, fourteen or even ten years ago, to prophesy that there would be nearly eight million holders of broadcasting receiving licences in the British Isles to-day. The popularity and success of our sound broadcasting service are due to the wisdom, foresight and courage of the Governors and staff of



Major the Right Hon. G. C. Tryon, the Postmaster-General, inaugurating the television service at Alexandra Palace

the British Broadcasting Corporation, to which the Government entrusted its conduct ten years ago. The Government of to-day is confident that the Corporation will devote themselves with equal energy, wisdom and zeal to developing television broadcasting in the best interest of the nation and that the future of the new service is safe in their hands.

"I was very glad, Mr. Norman, to hear your reference to the guidance and encouragement you have received from Lord Selsdon and the members of the Television Advisory Committee. We in the Post Office know well how unsparingly Lord Selsdon has devoted his great ability and high personal qualities to the public interest, both as Postmaster-General and on the Television Committees. I am very pleased that, under his guidance, the Post Office has been able to cooperate, through the Television Advisory Committee, in the development of this new service.

"I also should like to pay a tribute to all those who

have devoted their talents and their time to solving the very difficult problem of television. We owe it to their skill and their perseverance in research that television has passed from the region of theory to the realm of practice.

"As you have said, Mr. Norman, television broadcasting has great potentialities. Sound broadcasting has widened our outlook and increased our pleasure by bringing knowledge, music and entertainment within the reach of all. The complementary art of television contains within it vast possibilities of the enhancement and widening of the benefits we already enjoy from sound broadcasting.

"On behalf of my colleagues in the Government, I welcome the assurance that Great Britain is leading the world in the matter of television broadcasting, and, in inaugurating this new service, I confidently predict a great and successful future for it."

Lord Selsdon

Lord Selsdon said:—

"Mr. Postmaster-General, Mr. Norman and viewers: I stand before you as representing both the Television Committee, which originally investigated the possibilities of this new field, and also the Television Advisory Committee, which continues to advise regarding its development. My colleagues and I much appreciate what has been said about our work, and I only wish that time and space permitted them to appear before this instrument to-day. In their name I thank you.

"It has rightly been said that the potentialities of this new art are vast and it is possible, for instance, to conceive of its being applied not only to entertainment but also to education, commerce, the tracing of wanted or missing persons, and navigation by sea or air. All these and more will, no doubt, in due time be tested, and some of them will arrive. The patient industry of inventors has helped us so far; now we hope that the kindly interest of the public will help us further.

"From the technical point of view I wish to say that my Committee hopes to be able, after some experience of the working of the public service, definitely to recommend certain standards as to number of lines, frame frequency, and ratio of synchronising impulse to picture. Once these have been fixed the construction of receivers will be considerably simplified but, meanwhile, do not let any potential viewer delay ordering a receiving set for fear that a change in these standards may put it out of commission almost at once.

It is an essential feature of the development plans that for two years after the opening of any service area no such change will be made therein. For at least two years, therefore, today's receivers, without any radical alteration, will continue to receive Alexandra Palace transmissions.

Just how wide this London service area will prove to be is difficult to say with absolute certainty. Roughly speaking, it will cover Greater London with a population of about ten millions or, again roughly speaking, a radius of more than twenty miles with local variations. There may be some surprising extensions—for instance—I should be unwilling to lay heavy odds against a resident in Hindhead viewing the Coronation procession.

In the light of experience here we shall proceed with

the location of a second and subsequent transmitting stations according as public interest justifies this course.

"Technically, Britain leads to-day, and we shall try, in the words of Sir Antony Gloster, to 'Keep our light so shining a little in front of the rest.' To-day's simple ceremony will live in History, and I am proud to have taken part in it."

The following accepted invitations to be present at the inaugural Ceremony:

Major the Rt. Hon. G. C. Tryon, M.P.	} H.M. Postmaster-General General Post Office
Lt.-Col. A. G. Lee, O.B.E., M.C.	
The Rt. Hon. the Lord Selsdon, K.B.E.	} Chairman, Television Advisory Committee
Sir Frank Smith, K.C.B., F.R.S.	
Colonel A. S. Angwyn, D.S.O., M.C.	} Television Advisory Committee
Mr. F. W. Phillips, C.M.G.	
Mr. O. F. Brown	
Mr. J. Varley Roberts, M.C.	
The Rt. Hon. the Lord Inverforth	} Chairman, Marconi-E.M.I. Television Company
Mr. H. A. White	
Mr. A. Clark	
Mr. L. Sterling	
Mr. I. Shoenberg	
Mr. G. E. Condliffe	} Marconi-E.M.I. Television Company
Mr. A. D. Blumlein	
Mr. C. O. Browne	
Mr. N. E. Davis	
Sir Harry Greer, D.L., M.P.	} Chairman, Baird Television, Ltd.
Mr. Harry Clayton	
Mr. J. L. Baird	
Major A. G. Church, D.S.O., M.C.	} Board of Directors, Baird Television, Ltd.
Captain A. G. D. West	
Captain W. J. Jarrard	

Mr. T. M. C. Lance	} Baird Television, Ltd.
Mr. B. Clapp	
Mr. J. D. Percy	
Mr. B. D. L. Mogridge	
Mr. C. E. Rickard, O.B.E.	} Technical General Manager, Marconi Wireless Telegraph Co. Chairman, Radio Manufacturers' Association Radio Manufacturers' Association President, British Movie-tone News London representative, Columbia Broadcasting System President, Institution of Electrical Engineers Chairman, Alexandra Palace Trustees
Mr. Edward E. Rosen	
Mr. L. M. Macqueen	
Mr. D. Grant Strachan	
Sir Gordon Craig	
Mr. César Saerchinger	
Mr. H. T. Young	
County Councillor E. J. Cawdron, J.P.	
The Lord Rutherford, O.M., F.R.S.	
Sir John Cadman, G.C.M.G., D.Sc.	
Mr. R. C. Norman	} Chairman, B.B.C.
Mrs. M. A. Hamilton	
Caroline, Viscountess Bridgeman, D.B.E.	} B.B.C. Board of Governors, Director-General, B.B.C. Deputy-Director-General, B.B.C. Controller (Engineering), B.B.C. Controller (Administration), B.B.C. Controller (Programmes), B.B.C. Controller (Public Relations), B.B.C. and other members of the B.B.C. staff.
Sir J. C. W. Reith, G.B.E., D.C.L.	
Vice-Admiral Sir Charles Carpendale, C.B.	
Sir Noel Ashbridge	
Mr. B. E. Nicolls	
Mr. Cecil Graves, M.C.	
Sir Stephen Tallents, K.C.M.G., C.B., C.B.E.	

The S.A.R.R.L. International DX Competition

CAPTAIN S. THORPE, ZS1AH, has sent us the following information on the DX competition to run concurrently with the Johannesburg Jubilee Celebrations.

This Society have organised a contest on the same lines as the Melbourne Centenary Contest organised two years ago by Australian amateurs.

The *Rand Daily Mail* has donated a trophy for presentation to the highest amateur scorer outside the African zone. While certificates will also be awarded to the winner in each country, or prefix zone. In addition, the following countries have been sub-divided into amateur districts. United States W1-W9, Canadian VE1-5, Australian VK1-8, so that the highest scorer in each of these 23 districts will receive a certificate.

For the purpose of computing scores, African amateurs will multiply the total points obtained by the number of countries or prefix zones worked. The three above-mentioned countries will provide a possible multiplier of 23, in addition to all other countries worked.

DX countries outside Africa will multiply the points obtained for exchange of serial numbers by the number of

African zones worked:—Angola CR6, Belgium Congo ON4, Northern Rhodesia VQ2, Southern Rhodesia ZE1, Madagascar FB8, Reunion FR8, Mauritius VQ8, Tanganyika VQ3, and the Union of South Africa ZS1-6, ZT1-6, and ZU1-6, making a total of 27 zones or a multiplier of 27.

Only one contact is to be made between stations on each band, but if an exchange of serials is not effected on the first contact, the two stations may contact again to complete exchange.

Amateurs in South Africa will endeavour to establish contact with DX stations and to prove a satisfactory QSO a serial number of six figures must be sent to, and acknowledged by the DX operator.

This serial number will contain a report based on the RST system for the first three figures, the balance of the number comprising a self-assigned number of three figures to be used by these stations throughout the contest.

When a complete exchange of serial numbers has been effected, both operators claim two points, with four points on 10 metres only. It is anticipated that the 10-metre band will be very

active during the period of the contest, and to ensure that this band will carry its fair amount of traffic, double points are to be awarded.

The contest period is to run over four week-ends of January, 1937.

The *Rand Daily Mail* trophy will be presented to the DX operator outside South Africa who returns the highest score. No prior entry need be made, but each competitor must submit a log at the conclusion of the contest. Entries should be addressed to South African Radio League, Box 7028, Johannesburg, South Africa.

On November 28 a working model of the Coronation procession will be transmitted in "close-up," so as to provide a life-size impression of the Coronation coach and the troops on the march. Constructed by two brothers, Messrs. Edward and Frank Offord, the model is 13 feet in length and nearly 3 feet high. When it is set in operation a 150-yard section of Westminster is shown, with soldiers lining the pavement and dense crowds behind. In a few moments, to the accompaniment of martial music, the procession comes into view—bands, infantry, Life Guards, and finally, the Royal coach, with the King's Watermen bringing up the rear.

PHILCO (U.S.A.) TELEVISION

Unknown to the greater part of the television world The Philco Radio and Television Corporation, of Philadelphia, U.S.A., have been carrying out television research work for over eight years. Here is a brief account of a recent demonstration by this concern.

By Our American Correspondent

TELEVISION in the United States received a new impetus recently when the Philco Radio & Television Company gave a demonstration to the Press. This company has carried on experimental



The Philco television receiver. The picture is observed in a mirror in the lid of the cabinet.

television work for eight years; a licence for visual broadcasting from station W3XE was obtained in 1932, and experimental broadcasts begun. Last month's demonstration used 345 lines, at sixty frames per second interlaced.

The Philco system presented nothing radically new in the use of the basic principles of electronic television. It is understood that Philco holds licences from the two outstanding American companies (Farnsworth and R.C.A.) which have done the basic research in this field. What Philco has done, and much credit is due its engineers for this achievement, has been to take these basic principles and work them up to a high degree of perfection.

The first part of the programme was received in the house of one of the engineers seven miles from the plant and studio. This was broadcast

at a frequency of 51 megacycles, while the frequency of the sound carrier was 54.25 megacycles. A channel width of 6 megacycles was used and the polarity of transmission was negative. The aspect ratio was 4 to 3, and the synchronising impulses were of the narrow vertical type, 20 per cent. of the vision signal was devoted to synchronising.

An interesting part of the demonstration was an interview via television between Boake Carter, a well known news commentator. Mr. Carter was seated in the Philco studio seven miles distant. He appeared upon the television receiver and through sound and vision made various comments on the news of the day. Then telephone communication was made with the room in which the demonstration was held, and Mr. Carter was interviewed by various people present.

The latest model comprises a sound and television receiver tuning over a frequency range of 42-86 megacycles. These receivers are separately tuned. A cathode-ray tube is used which is 12 inches in diameter and 19 inches long. This is placed in the cabinet in an upright position and the picture is seen through a mirror on the inner side of the half raised cover. Deflection is electromagnetic. The power supply units are placed in the bottom of the cabinet. The total number of valves is 36.



It is claimed that this is an untouched photograph of a picture on the screen of a Philco receiver.

While the officials of the company refused to estimate the cost of the receiver, when offered to the public, a tentative figure of \$500 was suggested. The opinion is held that the costs of the first receivers was not

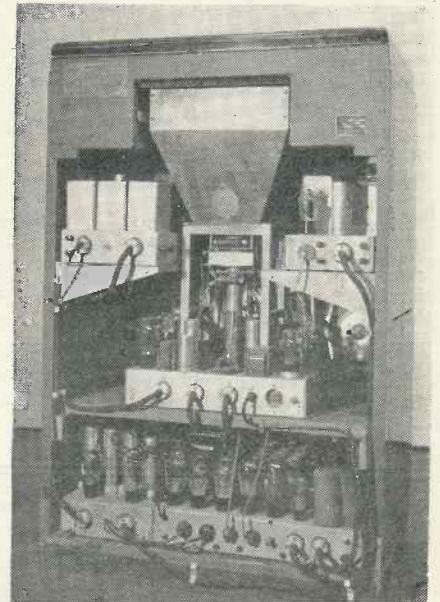

A rear view of the receiver with the back removed.

nearly so important as other figures in television, namely, the cost of programmes, transmission, etc.

Cossor Television Receivers.

In the article entitled "Television Receivers You Can Buy," which appeared in last month's issue on page 631, it was stated in a reference to the Cossor receivers that "a second receiver for those who already have a broadcast set" is available for 105 guineas—the Model 137 T. The inference is that this receiver is designed for television and the accompanying sound only, whereas actually it gives broadcast reception on medium and long waves in addition.

Model 237 T, which sells at 120 guineas, provides vision and sound for television and also broadcast reception on the medium and long waves. In addition this model has an automatic record changer and gramophone motor.

TELEVISION IN THE HOME

AERIAL INSTALLATION; OPERATION—AND SOME FIRST EXPERIENCES

By the Editor

THE prospective purchaser of a television receiver need have no concern regarding installation. Really the only vital matter is whether you have electric supply available. If you have, whether it be D.C. or A.C., then you can have a television receiver providing, of course, that you are within the service range of the Alexandra Palace.

My own choice was a G.E.C. receiver and before delivery was due I had schemed out what I thought would be the best aerial layout under the somewhat exacting conditions. However, I could have saved myself the trouble for the G.E.C. installation engineers came fully equipped to meet all manner of aerial conditions and proceeded forthwith to carry out a number of tests in order to arrive at the best arrangement.

The particular problem was that the house is situated on a main road which carries a heavy stream of motor traffic. In the first instance it was thought that by attaching the dipole aerial to a high chimney at the back of the house it would be sufficiently removed from the field of interference. This position meant that the aerial would be approximately sixty feet from the road and at a height of about thirty-five feet, a concentric feeder brought down the side of the house being used as a lead-in.

Preliminary tests with this arrangement did not satisfy the G.E.C. engineers and it was decided to remove the dipole to the greatest distance possible from the road. Incidentally it should be noted that even with the aerial in this first position, interference was not impossible to tolerate, but it was irritating when traffic was particularly heavy. Under the more ordinary conditions of suburban side roads it would be hardly observable, a fact which disposes of the point

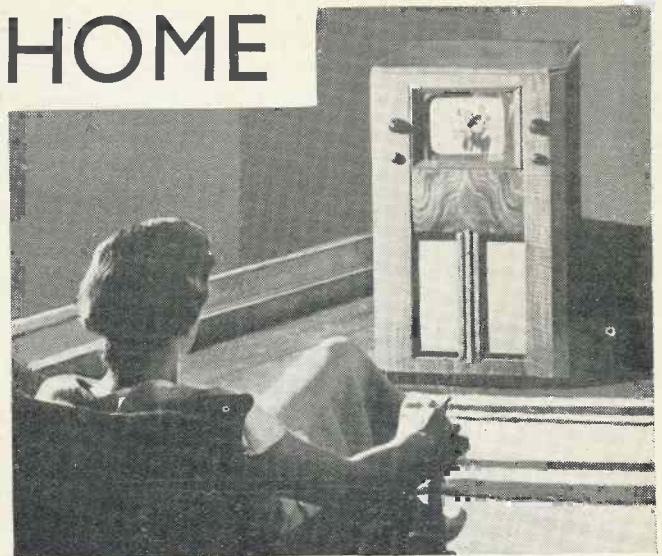

that under most ordinary conditions interference is likely to be troublesome. Even at its worst it affects the sound much more than the vision, or rather it would be more correct to say that it is more noticeable with sound than vision.

Cutting Out Interference

In order to instal the aerial at the greatest possible distance from the road, a mast with a dipole attached was erected at the extreme end of the garden. This mast was actually a large size in wireless masts and when erected the dipole was about forty feet above ground level. The lead from this was a concentric feeder brought down the mast and then carried along the top of the fence and at a few yards from the house taken up to and in the top of a ground-floor window.

When a preliminary test was made with this arrangement a remarkable improvement was immediately noticeable and it is now only on rare occasions that any serious interference is apparent. It is an evident fact that some makes of cars are more prone to cause

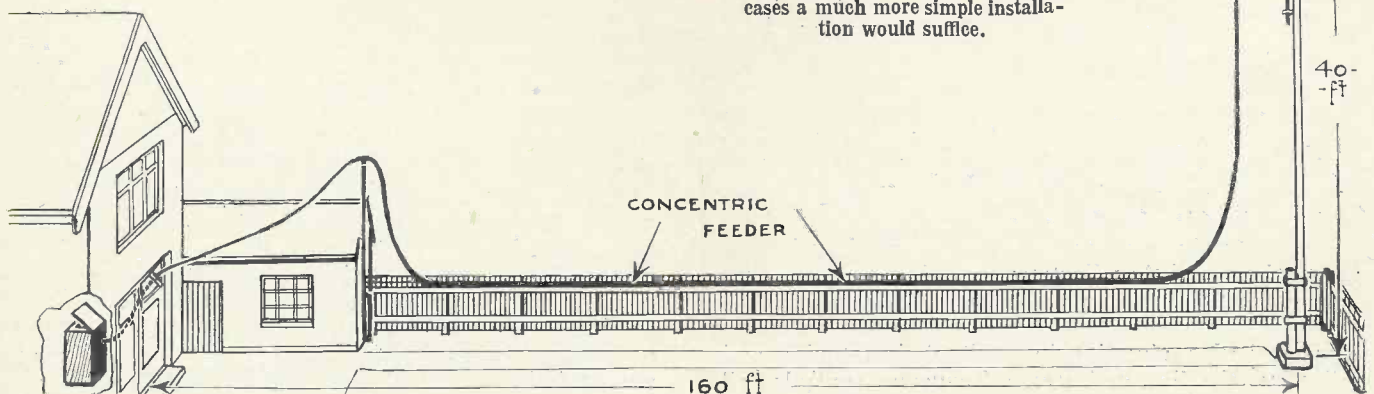

This aerial arrangement was necessitated by a large amount of main-road motor traffic. In most cases a much more simple installation would suffice.

COMPLETE BROADCAST ENTERTAINMENT

interference than others. At a later date it is hoped to list these; observations so far indicate that the Ford 8 and the Riley are rather bad offenders, but as no detailed check has been made this opinion may have been formed purely by coincidence.

Although with this arrangement interference is practically nil, it is hoped later on to eliminate it altogether.

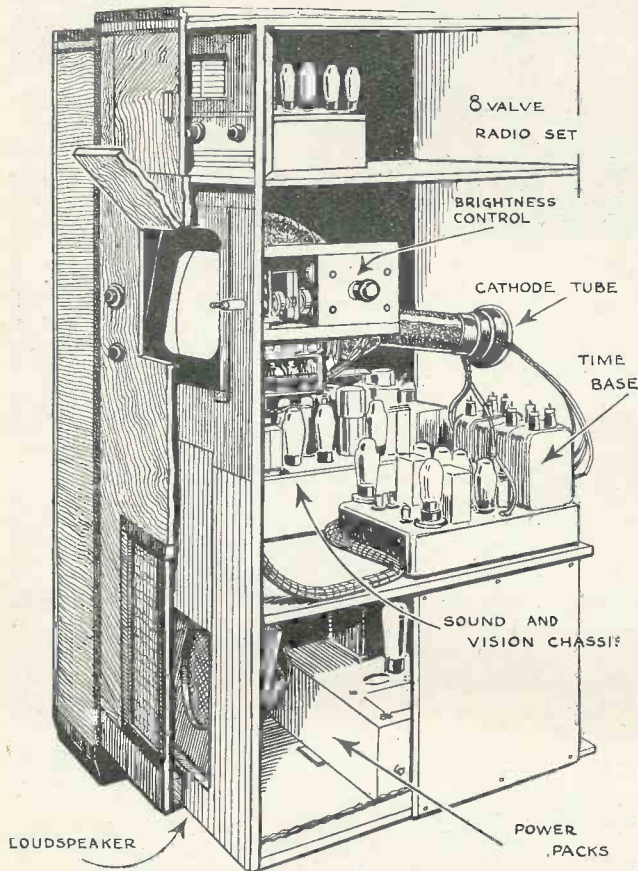

A cut-away view of the G.E.C. television receiver showing the arrangement of the various units. This is the model incorporating a short-medium- and long-wave receiver.

The G.E.C. engineers suggested several easily adaptable schemes. It was concluded that what little bit of remaining interference there was was being picked up on the feeder itself and therefore that if this were placed almost at ground level, instead of being on the top of the fence, further improvement would be effected. Alternatively the feeder could be buried in the ground; or another suggestion was the earthing of the outer casing of the feeder. From an academic point of view, rather than any practical necessity, it is hoped to experiment in this direction at a later date.

One naturally expects that when a receiver is first installed some little adjustment will be necessary, but this was not the case; an effort was made to complete the aerial installation during one of the test transmissions and after plugging in to the mains, tuning and adjusting the line and frame frequency controls (all perfectly simple operations), the picture appeared and

remained quite steady for the entire duration of the programme.

Perfect Safety

A great point has been made in the past regarding the dangerously high voltages that are used in a cathode-ray receiver. It cannot be too strongly stressed that there is not the slightest possibility of danger; a child could play with one for hours and not come to the slightest harm. Even if the back were removed, the connections are automatically broken and in ordinary use no high voltages are even remotely accessible.

As is well known the G.E.C. make two types of television receiver—one intended for the reception of sound and vision only from the Alexandra Palace and the other, which in addition to sound and vision reception of the Alexandra transmissions also incorporates a long, medium and short-wave receiver for sound transmissions. It was thought desirable to have the latter type as representing the last word in broadcast entertainment, though I must admit that my chief interest lies chiefly in the television section.

One master switch controls all receiver sections—to the left it switches on the long, medium and short waves; the first position to the right cuts out the broadcast sound and makes it suitable for reception of the Baird system (both vision and sound); a further turn to the right and it is suitable for the Marconi—E.M.I. system—again both vision and sound. Apart from the tuning knob of the broadcast receiver, usually this is the only control that need be touched, although there are tuning, volume, contrast and line and frame frequency controls for the television section mounted on the front of the cabinet.

The broadcast sound receiver is a separate receiver to all intents and purposes and is accommodated in the upper part of the cabinet. This is provided with the usual single-knob tuning, wavechange switch, and tone and silent tuning controls. Both this section and the end of the cathode-ray tube are enclosed by flush-fitting doors and externally the cathode-ray tube is further protected by a glass window.

A Complete Home Entertainer

The performance of this receiver is amazing. Practically any European broadcast transmission is available at full loudspeaker strength, and most short-wave stations also with full loudspeaker volume. The volume, when the control is turned full on, is sufficient to shake the house. No less amazing is the simplicity so far as operation is concerned. Although the complete receiver may be said to perform six functions it is as simple to operate as an ordinary wireless receiver.

At this early stage of television transmission it is but natural that variations should occur and on these occasions there is always the inclination to attempt adjustments of the receiver. It is noteworthy, however, that in no case has this been actually necessary and a reversion to the original setting at a later stage of the programme, when conditions had altered, proved that any variation that had occurred was not in any way due to the receiver.

FOR THE BEGINNER



By A. F. Hollins, Mullard Technical Service Dept.

II—FOCUSING AND SPOT SIZE

It is first of all necessary to realise that focusing and spot size, both of which have an important bearing upon the definition of a television picture or of the trace of some phenomenon which is being investigated by means of the cathode-ray tube, are two separate effects, although the effect of incorrect focus is, to some extent, similar to that of permitting an increase in spot size. Focusing being the major problem, it will be considered first.

There are three methods available for focusing cathode-rays, namely, gas focusing due to the effects of the residual gas within the envelope; electro-magnetic focusing; and electro-static focusing. All are of sufficient importance to justify detailed consideration and each has its own particular sphere of usefulness, although the two last mentioned, as applied to "hard" tubes, are of greater interest to readers of TELEVISION AND SHORT-WAVE WORLD; electro-static focusing, which is employed in the particular forms of tube under discussion must be dealt with in the greatest detail.

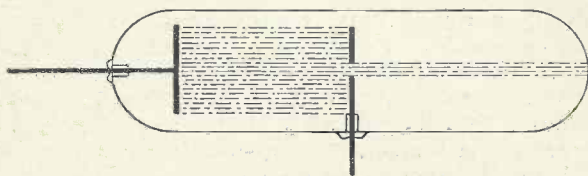

Fig. 1.—An early design of tube for producing a stream of electrons.

The various problems which arise will be more clearly understood by bearing in mind two of the fundamental facts concerning the cathode-rays, namely, that they emerge in straight lines normal to the cathode (in this respect they are, of course, analogous to light rays) and that they carry a negative charge. These two points are taken advantage of in all focusing devices as will be shown.

Gas Focusing

It should be remembered that the cathode-ray tube was evolved from the early "vacuum" tubes (in reality they contained considerable quantities of residual gases) which were made for the examination of electrical discharges. These tubes had cathodes of the cold emitter type and in many cases consisted merely of an evacuated glass tube with a flat electrode sealed in at each end. It was only when qualitative experiments gave place to quantitative research that any attempt was made to produce a "ray" in the sense of a pencil or concentrated beam of electrons.

Fig. 1 shows an early design of tube for producing an electron stream of small dimensions, and it should be noted that no attempt is made to concentrate the total emission from the cathode into a beam, all that is done is to cut off the more divergent parts of the beam, utilising only the area corresponding to the size of the aperture in the anode. The energy of the beam on the side

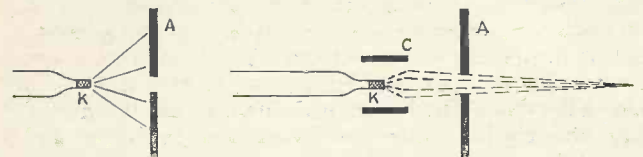

Fig. 2.—Two diagrams showing how the electron beam can be concentrated by the use of an electric field.

of the anode remote from the cathode is, therefore, but a fraction of that of the total emission, and an interesting parallel can be drawn by referring to the light value in a camera which is decreased by "stopping down."

Later the Braun tube was developed and from these early efforts the "soft" cathode-ray tube emerged in a form similar to that employed to-day. An electrode was introduced into the soft tube in the form of a

MAGNETIC FOCUSING

cylinder surrounding the cathode, its object being to concentrate the electron stream leaving the cathode, in order to ensure that practically the whole of it passed through the anode aperture.

Fig. 2 shows on the left how the electrons would be scattered in the absence of the cylinder, and on the right how the electrons are concentrated under the influence of the electric field inside the cylinder. It will be clear, therefore, that the potential applied to the cylinder controls not only the initial divergence, but also the intensity of the ray, and these two factors determine the sharpness and definition of the spot for a given type of tube structure and gas pressure.

But a still more important factor in concentrating the beam is the effect of the residual gas within the tube.

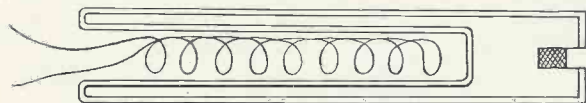

Fig. 3.—Diagram showing the arrangement of the emitting surface in a gas-focused tube.

A quantity of gas at a pressure of about 0.005 mm. is introduced into the bulb of a "soft" tube for two reasons. One is to permit the use of fairly low operating voltages of the order of 300 to 2,000 volts, and the other is for focusing the beam. The gas employed may be hydrogen, helium, neon or argon. While passing from the cathode to the anode the electrons "ionise" the gas atoms, that is to say, as the result of collisions between electrons and gas atoms, each of the latter is split up into a positive ion and one or more electrons. Now the positive ions have a far greater mass than electrons and their velocity is therefore much lower so that they remain in the path of the ray for a much longer time than the electrons. The positive ions therefore form a positive space charge in the centre of the ray and, because this charge exercises an attractive force on the electrons, the ray is concentrated. It is for this reason that the "soft" tubes are more correctly termed "gas-focused" tubes.

In the construction of gas-focused tubes precautions are taken to shield the emitting surface of the cathode from bombardment by the positive gas ions which would otherwise result in the rapid disintegration of the emitting material. One method of doing this is illustrated in Fig. 3, which shows a cathode in which the emitting surface is recessed within the body of the cathode structure. The form of heater winding adopted should also be noted.

Limitations of Gas-focused Tubes

Gas-focused tubes are entirely satisfactory for a large number of applications, but their performance is not ideal when very rapid deflection of the ray is required as in the investigation of high-frequency phenomena and in television. The reason is that under these conditions the ray does not remain in any one spot for a sufficient period to permit the formation of enough positive ions for satisfactory concentration, with the result that the image becomes blurred. For these types of applications, also, the gas-focused tube has the further disad-

vantage that the sharpness of the image is largely dependent upon the intensity of the ray. But as picture modulation in the present day form of television transmissions is introduced by varying the strength of the beam current, the focusing effect is being constantly varied, and with it the sharpness of the picture.

Two other effects characteristic of the gas-focused tube are first, the departure from linearity of the deflection characteristic when the field between the plates is reduced below a critical value, and the low value of the impedance between the deflecting plates due to the ionic current. However, both of these effects can be avoided either by modifying the normal construction of the tube or externally by adjustment of the electrical circuit connected to the tube.

Magnetic Focusing

Of the methods of focusing the beam in a cathode-ray tube of the highly evacuated type, magnetic focusing first demands attention. The basic principle employed is that if the tube is surrounded by a coil arranged with its axis co-incident with the path of the undeflected ray and a direct current is passed through the coil, the longitudinal magnetic field produced, acting upon all electrons which are not travelling exactly in the axial direction, compels them to follow curved paths. By correct location of the coil and correct adjustment of the magnetising current, these curved paths can be made such that electrons emitted from the cathode are brought to a focus at one particular point on the screen.

The following data are of interest in the correct application of magnetic focusing. Assuming that the focusing coil is in the form of a solenoid which is short in comparison with the length of the beam, and that the diameter of the beam as it enters the region of the coil is small, the ratio of the diameter of the spot at the screen

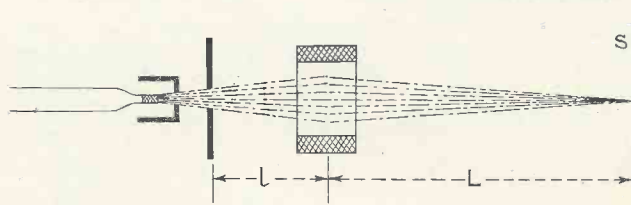

Fig. 4.—Diagram showing the principle of magnetic focusing.

to the diameter of the beam aperture of the anode will be L/l where: L is the distance from the centre of the coil to the screen and l is the distance from the centre of the coil to the anode as indicated in Fig. 4. Although, on this fact alone, it would appear that the coil should be as near the screen as possible, there is a conflicting factor in that as the coil approaches the screen, so the diameter of the beam at incidence at the coil increases, due to beam divergence. The electrons forming the outer edges of the beam will therefore have a different focal length from that of the innermost electrons, and a blurred spot will result, analogous to the spherical aberration experienced in an optical system. A compromise must therefore be effected between the distances L and l , the final decision depending upon the spot size required and the size of the beam aperture at the anode.

FOCUSING THE ELECTRON BEAM ELECTROSTATICALLY

The magnetising force required, that is to say the number of ampere-turns of the coil itself (number of turns multiplied by the magnetising current in amperes), can be computed approximately from the following formula:

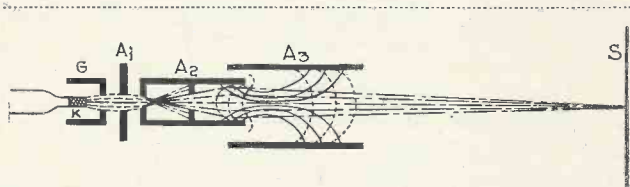

Fig. 5.—The arrangement of a 3-anode tube and their effect upon the electron beam.

$$N = \sqrt{\frac{V(1+L)d}{1 \times L}} \times 220$$

- Where: N number of ampere-turns
 V anode voltage in kilo-volts
 L distance between centre of coil and screen in centimetres
 l distance between centre of coil and anode, in centimetres
 d mean diameter of coil in centimetres.

For a medium-sized tube the magnetising force will be of the order of 250 ampere-turns. In practice the number of ampere-turns may be considerably decreased by concentrating the magnetic field by means of an iron yoke terminating in an annular gap concentric with the neck of the tube.

Electro-static Focusing

It will have appeared, from the previous paragraphs, that electro-magnetic focusing has certain characteristics in common with the focusing of light by means of a lens; electro-static focusing also makes use of an electron-lens effect. The subject of electron-optics is too vast to be covered here, and it must suffice to explain that, by suitable shaping the electrodes, it is possible to produce an electro-static field of symmetrical shape such that electrons diverging from a given point are brought to a focus at some other point. As in magnetic focusing, the focal length and ultimate spot size are governed by the relative positions of the electrodes and the strength of the focusing field.

The photograph reproduced herewith (page 683) shows details of the electrode system of a Mullard cathode-ray tube, and attention is particularly drawn to the view showing a longitudinal section of the electron lens assembly which in this instance is that of a two-anode tube. Reference to Fig. 5, which shows the beam outline for a three-anode tube when adjusted for correct focus will facilitate appreciation of what actually takes place.

It will be observed that initially the beam is convergent at the second anode, which means, in effect, that the electron lens has something approximating to a point source of electrons upon which to operate. At the second anode the beam diverges again, but under the action of the electro-static field between the second and third anodes it again becomes convergent, being finally brought to a focus at the screen.

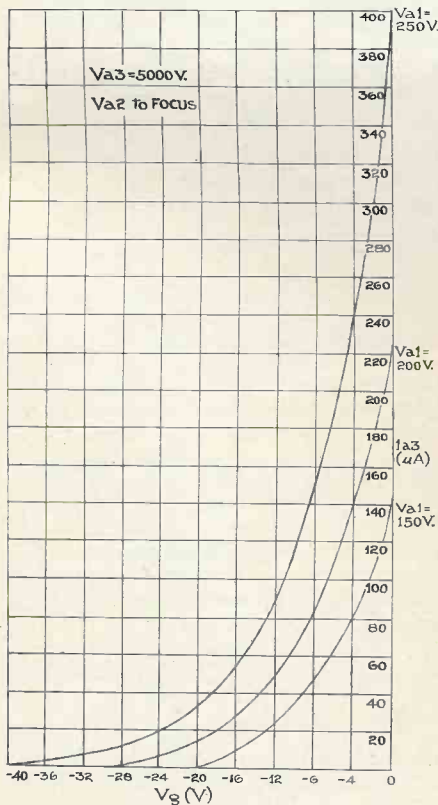

Fig. 6.—Curves showing the variation of beam current with variation of grid voltage for different values of V_{a2} .

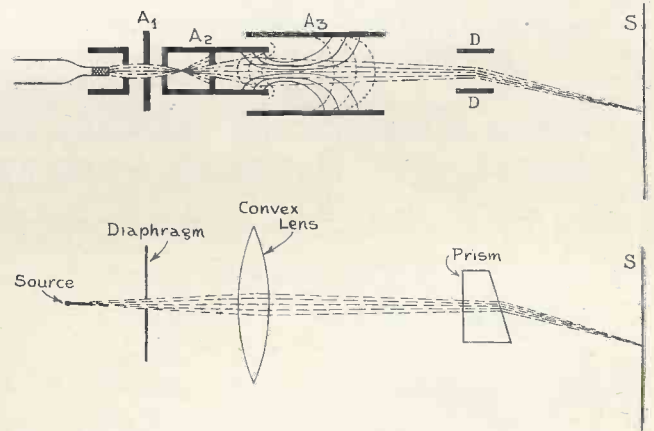

Fig. 7.—Two diagrams showing comparison between electronic and optical focusing.

Referring again to Fig. 5, the cathode, which approximates to a point source, provides the electron stream; surrounding it concentrically, and designed to produce a powerful controlling effect is the grid which introduces the necessary modulation of the beam current. Immediately in front of the grid is the first anode which provides the initial accelerating impetus and also acts in a similar way to the screening grid of a radio valve in that it ensures that the electro-static field of

(Continued on page 704)

ELECTRON MULTIPLIER RESEARCH

RESEARCH on the development of electron multipliers is being conducted in practically every electrical laboratory in the world and some results have recently been published of work undertaken by the German Post Office.

Experiments were made with a view to finding the most suitable metal for the targets—that is metal

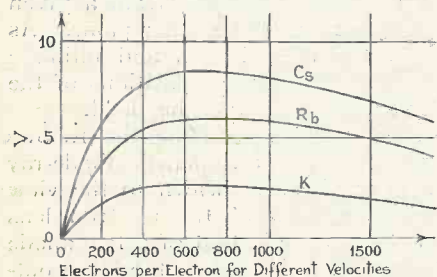

Fig. 1.—The number of secondary electrons produced at different voltages.

that would yield the greatest number of secondary electrons. Knowledge of photo-cell characteristics suggested that the alkali metals would be the most suitable, particularly cesium deposited on oxidised silver, with which a maximum of 8 to 10 electrons per electron is obtained at about 600 volts. Of other metals examined (gold, lead, iron, aluminium, sodium, copper, zinc, etc.) only magnesium was found to give a satisfactory yield.

Targets of finely meshed wire gauze, placed one behind the other, with a potential difference of 50 volts between them, were used; the elec-

trons set free at each electrode being concentrated by a magnetic field with lines of force perpendicular to the electrodes.

With gauze of threads, having 10,000 meshes per sq. cm.; with about half the area occupied by threads, it is possible to obtain a magnification of about five per stage. The plate, at 400 volts, is made of wider mesh, and is followed by a series of grids with decreasing potentials (Fig. 2). Tubes giving an amplification of one million are now possible.

In the Farnsworth secondary emission multiplier the electrons are made to go back and forth between a single pair of targets receiving their potential from a high frequency electric field applied to the targets. Suppose that electrons are liberated by ultraviolet light at the moment the voltage of the second target goes from negative to positive values. If the time taken by the electron to cover the distance between the targets is exactly equal to $\frac{1}{2}$ period, the electron will be accelerated throughout its path by the electric field, and knock electrons off the second target which acted as anode. Three electrons are drawn to the first target during the second half of the period, and produce additional secondary electrons which repeat the cycle.

An electron which is set free by the light after the second target has reached a certain positive potential may make part of its lag good because it starts in a stronger field. Neglecting space charges and collisions, the

simple equations of motion show that as long as the lag does not exceed about one-sixth of the whole period of oscillation, the lag or phase difference with which the secondary electrons are set free decreases in each successive crop of electrons. When the lag becomes considerable the electron arrives in the wrong phase and is retained by the second target.

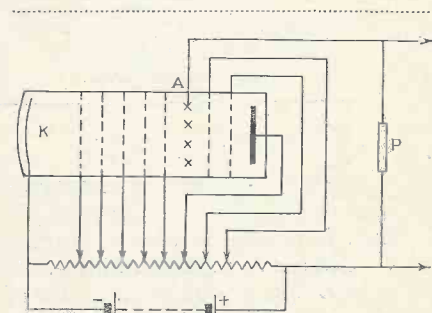

Fig. 2.—Diagram of mesh-type multiplier.

The electrons set free during the first third of the first half wave come gradually into step with the applied field; the velocity with which they arrive at the electrodes depends, of course, on the phase with which they started. The velocity of the electrons with a lag of 45 deg. is only about one-half the highest velocity. With a given tube the degree of amplification may be adjusted by increasing the frequency of the applied field, the cut-off being obtained for an increase of about 10 per cent., or by decreasing the amplitude.

"A Q.P.P. 70-WATT POWER AMPLIFIER."

We very much regret an error which appeared in the article in our November issue on page 658 under the caption "A Q.P.P. 70-Watt Power Amplifier," which contained the statement that "A suitable transformer for this purpose can be obtained from Mr. N. Partridge, of Messrs. Bryan Savage, who have had considerable experience with this type of work." It was our intention to say that Mr. Partridge or Messrs. Bryan Savage supplied this transformer, but a printer's slip made us say "of" instead of "or," our statement then carrying with it the inference that Mr.

Partridge was connected with Messrs. Bryan Savage. We are assured by Mr. Partridge that he carries on a business (entirely separate and apart from Messrs. Bryan Savage) as a specialist in the design and manufacture of transformers at King's Buildings, Dean Stanley Street, London, S.W.1. We apologise for the mistake.

Special Aerials for the Amateur

Now that the average amateur appreciates the need for an efficient aerial system there is considerable interest in low-loss cable for use as feeder lines. Most matched impedance aerials require a special cable if they are to work

effectively and up to the present not all the cable available in this country has been entirely satisfactory.

Messrs. Eves Radio, Ltd. of Wolverhampton, have supplied us with some very fine cable which from our tests seems to be entirely suitable for amateur use.

It is built up from two separate 1/064 solid conductors each double vulcanised, colour graded, twisted and then enclosed in a final heavy gauge waterproof covering. This cable sells at 4½d. per foot or 4d. per foot over 50 yard lengths.

Also available from the same source are the new RK35 valves and the Western Electric type WE316A transmitting acorns suitable for frequencies up to 750 megacycles. All publications of the A.R.R.L. including the 1937 Handbook are now available.

BAIRD TELEVISION LTD.

**WORLD PIONEERS & MANUFACTURERS OF
ALL TYPES OF TELEVISION EQUIPMENT**

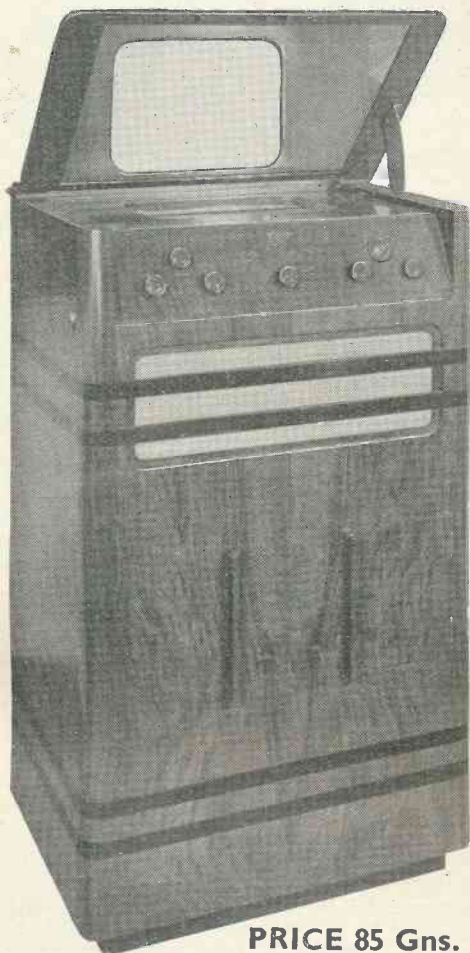

PRICE 85 Gns.

BAIRD TELEVISION, LIMITED, announce that their "Televisor" receiving set Model T.5. is now ready for immediate delivery from stock.

Authorised dealers who have qualified for a Baird Certificate of Proficiency, have been appointed within the service area of the B.B.C. television station. A complete list will be supplied on written application to the Company at Crystal Palace.

"Televisor" receiving sets give a brilliant black and white picture 12" x 9" on the "Cathovisor" cathode ray tube, which is of unique design and guaranteed for a long life.

These Sets give results on both systems of transmission unequalled in size, detail, brilliance and colour, with the accompanying sound, and are operated on A.C. Mains, or on D.C. Mains with a suitable D.C./A.C. converter. The controls are extremely simple for either system.

"TELEVISOR" RECEIVERS MIRROR THE WORLD

Head Office :

**GREENER HOUSE,
66, HAYMARKET,
LONDON, S.W.1.**

'Phone : Whitehall 5454

TELEVISOR

REGISTERED TRADE MARK

Studios and Laboratories :

**CRYSTAL PALACE,
ANERLEY ROAD,
LONDON, S.E.19.**

'Phone : Sydenham 6030

TELEVISION

for the Home Constructor

TO-DAY, television, the new wonder of the age, is fast becoming generally available to the public and a fascinating new world of interest is presented to those for whom the home construction of radio sets has held so much attraction in the past. Television is bringing a living cinema to every fireside, and is opening up a vast and thrilling new field of home entertainment. During the coming months, there will be many historic features in the programmes. Already variety, news-reels, ballet, and novel illustrated talks are included. Soon there will be the thrill of seeing and hearing at the actual moment of occurrence events of the Coronation of King Edward, not to mention other great national occasions and such annual favourites as the Derby and the Boat Race.

WITH the establishment of regular B.B.C. programmes from the Alexandra Palace, BOSCH HALL have decided to offer a range of units which will enable the home constructor to enjoy excellent television at a considerable saving in cost. These units are designed to give good results within a radius of 50 miles of the Alexandra Palace, and are as easy to assemble as an ordinary radio set. Each unit is supplied with clear diagrams and instructions, and can be fitted into a cabinet of the purchaser's own selection.

Constructors have the choice of buying Vision or Sound Receivers, Time Base, or Power Pack Units, assembled and ready for linking up in one cabinet, or the complete kit of parts of each unit for home assembly. The instruments work on A.C. mains 100/240 volts, and the local voltage should be stated when ordering. All the material is of the finest quality and is British made throughout. Prices and particulars are given on the right, and the fullest information will be sent on request.

THESE units have been designed by Mr. Charles P. Hall, B.Sc., a Fellow of the Television Society, and one of the leading authorities on television matters. BOSCH HALL definitely guarantee that, providing the units are assembled in accordance with the simple directions, the results will give the utmost satisfaction. To help any constructor who experiences the slightest difficulty, the expert advice of the company's service bureau is freely available. This bureau has for its main object the encouragement of those amateur experimenters whose valuable work in the development of modern radio is widely acknowledged. Furthermore, by arrangement, sets assembled by constructors can be inspected and tested by a qualified engineer on a payment of a small charge.

Be one of the first to build your own television receiver. By making the instrument yourself, you will treble your enjoyment when you sit down to watch and hear the television programmes. Start now—write to-day for further particulars, gladly sent free on request.

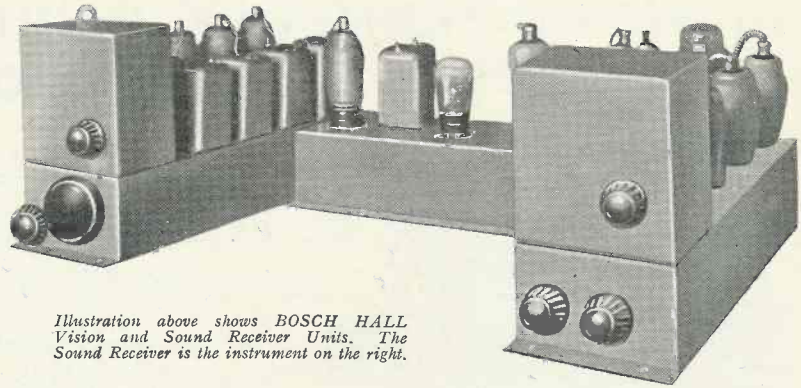

Illustration above shows BOSCH HALL Vision and Sound Receiver Units. The Sound Receiver is the instrument on the right.

Vision and Sound Receivers

The BOSCH HALL Vision Receiver gives high definition on ultra short waves as used for the B.B.C. Alexandra Palace programmes. It embodies an amplitude filtering circuit dividing the synchronising signals and providing separate outputs for the Time Base and the Sound Unit. The instrument uses nine valves. The five-valve Sound Receiver gives perfect reproduction and remarkable ease of control with freedom from interference.

VISION RECEIVER: Chassis assembled, and complete with nine valves, £18 18s. 0d. Kit only, with drilled chassis, for home assembly, less valves, £8 15s. 6d.

SOUND RECEIVER: Chassis assembled, and complete with five valves, £14 14s. 0d. Kit only, with drilled chassis, for home assembly, less valves, £7 12s. 6d.

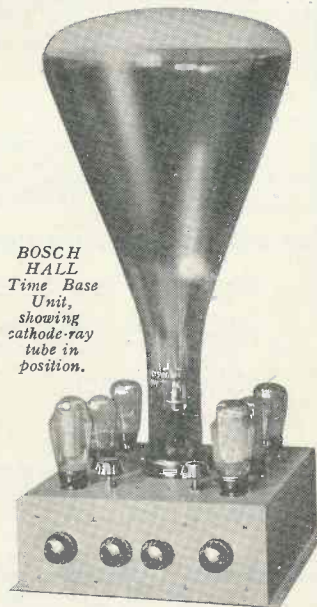

BOSCH HALL Time Base Unit, showing cathode-ray tube in position.

Time Base

Produces from B.B.C. transmissions a bright and distinct black and white picture, size, 10 in. by 7 in. Highly efficient scanning. Brilliance of image variable at will. Designed for vertical use with reflecting mirror. Chassis assembled, complete with six valves, £17 17s. 0d. Kit only, with drilled chassis, for home assembly, less valves £9 15s. 0d. Cathode-ray tube, extra, in both cases.

Power Pack

Incorporating potential divider unit for supplying H.T. to anodes of cathode-ray tube at 400, 1,250 and 4,000 volts, and negative grid bias of 150 volts. Built in metal screening box and fitted with safety switch. Operates on 100/240 volts, A.C. supply. Chassis assembled, complete £10 10s. 0d. Kit only, with drilled chassis, for home assembly, £6 6s. 0d.

INTERMEDIATE FREQUENCY UNITS for vision receivers, operating on wavelength of 7 megacycles, giving "flat top" response averaging 2 megacycles in bandwidth. Each, 10/-.

BOSCH HALL Television

BOSCH HALL LTD., FERRY ROAD, TEDDINGTON, MIDDLESEX. TELEPHONE KINGSTON 6556

Scannings and Reflections

TELEVISION DEMONSTRATIONS

DEMONSTRATIONS of television are being given to the public at a fairly large number of centres in London. The General Electric Co., Ltd., have two large demonstration theatres in Magnet House, Kingsway, where both the afternoon and evening programmes may be seen. H.M.V. have also two large theatres at their showrooms at 98 Clerkenwell Road. Baird Television give demonstrations at their offices in Greener House, Haymarket.

In addition to these manufacturers' demonstrations, several of the large stores are equipped with receivers. Among these are John Barnes, Finchley Road; Wallis's, of Holborn; Gamages, also of Holborn; Whiteley's, Westbourne Grove; Arding and Hobbs, St. John's Road, Clapham Junction; and Kennards, of Croydon and Wimbledon. Many wireless dealers are also giving demonstrations, and among these are E. Rogers and Sons, High Street, Weybridge, and Radio and Electrical Equipment Renters of the Parade, High Street, Watford. Weybridge, of course, is on the fringe of the estimated service area, but nevertheless reception there is excellent.

The Southern Railway are still giving demonstrations to railway ticket holders at Waterloo Station and the Science Museum demonstrations are also to be continued until further notice. The latter have created an enormous amount of interest and very many thousands of people have witnessed them.

RECEIVER SALES

The demand for television receivers has exceeded makers' expectations, and in every case it has been found necessary to make arrangements to increase the output. It was generally expected that the demand at first would be confined largely to stores and institutions, but there are sound indications that the public is becoming keenly interested, and many private sales are being effected. Many

people are delaying purchase in the expectation that with increased output prices will fall. Eventually this will be the case, but not until the demand warrants mass production methods on a fairly large scale. It must be remembered that a television receiver largely follows ordinary wireless practice and employs similar components and the production of a large part of the receiver is, therefore, based upon practice which has been gained over a number of years and on which there is little prospect of effecting a saving.

TRANSMISSION RANGE

Although no precise data is as yet available regarding the range of the Alexandra Palace transmissions, it is clear that, generally speaking, it is considerably in excess of that officially given. Pictures have been received as far distant as seventy-five miles and we have reports of reception at Leigh, approximately thirty-five miles away. Reception appears to be consistently good in the whole of Greater London and so far as we are aware no difficulties have been met with within a radius of thirty miles. It is understood that manufacturers of receivers are prepared to make tests of the suitability of location within reasonable distances.

TELEVISION ON TAP

Carrington House, a large block of flats in Mayfair, has been equipped for "bulk reception" of television signals and of ordinary broadcast programmes. The building contains seventy-three flats, each of which is fitted with plug points for television and radio reception. The residents of any of these flats can purchase a television and/or radio set in the confident knowledge that it will operate successfully and provide programmes quite free from interference.

Two aerials have been erected on the roof, both of which have been specially designed by E.M.I. Service, Ltd. That for broadcast programmes is matched to the transmission line which connects to the amplifier, whilst for the reception of the television

signals an aerial of the half-wave dipole type is employed. Leads from these aerials go direct to high-frequency amplifiers employed to magnify incoming signals and to meet the load imposed upon the line as well as to offsetting line losses.

A high frequency co-axial cable is employed for distribution. The outputs of the radio and television frequency amplifiers, in addition to being matched to the line impedance are mixed and the various frequencies superimposed on each other and carried over the same conductor. By correct attenuation and termination, reflections are avoided and a constant load maintained. At the outlets in the rooms, separation of the television and radio frequencies takes place and whichever service is desired can be taken from the appropriate sockets. Television reception, even in the ground floor flats, is as good as if each flat had its own aerial situated on the roof.

TELEVISION THE CORONATION

The Television Director has fully realised what an enormous boost would be given to television were it possible to televise the actual Coronation ceremony in Westminster Abbey. Such an event presents some very difficult problems at the present stage, but these problems are already being tackled and it is thought that they can be overcome. The two great difficulties are those of relaying the signals to the Alexandra Palace and the matter of adequate light. There are two possible solutions to the first—a special cable from the Abbey to Broadcasting House which would link up with the existing cable from there to the Alexandra Palace or the relaying of the signals by microwaves. Comparatively little experience has as yet been obtained with either method and both are undergoing investigation.

The question of light is one that concerns the authorities, who are not disposed to allow more than a certain maximum value and the point for the B.B.C. engineers in this matter is

MORE SCANNINGS

whether this value will suffice. It is understood that negotiations are proceeding with a view to getting this point settled and in the meantime experiments are being carried out. At the present time it is not possible to give any pronouncement one way or another, though the general indications are that the Coronation will be televised and that many thousands of people in the service range of the London transmitter will have the opportunity of seeing it.

NO TRANSMISSION CHANGES FOR TWO YEARS

The statement by Lord Selsdon at the opening of the television service that there will be no change in the standards used for transmission which would render existing receivers obsolete for at least two years is an important one for it will do much to stabilise production.

OUTSIDE BROADCASTS

The average viewer is quite unaware of the work entailed in an outside television broadcast even of the most ordinary kind. For example, the pictures of the North London Exhibition which were transmitted during the test period involved several days' work for the engineers and a staff of about twenty-five actually at the time of the transmission. Special lighting arrangements had to be made and this necessitated a portable cable system with men paying out the cables as the camera was moved from stand to stand; in addition there was the high-frequency cable connecting the camera to the transmitter to be handled so that the whole transmission provides a decidedly complicated job of work.

ALEXANDRA PALACE PROGRAMMES IN SOUTH AFRICA

It is reported that a Johannesburg amateur is regularly picking up the Alexandra Palace transmissions in that town. It is stated that he has heard the announcing and programmes since the middle of October. The vision sounds (synchronising) are also heard, but as no receiver is available it has been impossible to try to resolve the pictures. Other reports of freak long-distance reception have been received, but owing to the inconsistency it has never been possible to obtain verification.

THE LONDON-BIRMINGHAM CABLE

The task of laying the special coaxial cable between London and Birmingham is now completed. The cable contains four wires and in the first place use will be made of only two of these for trunk telephone communication, though it will be some weeks before the cable is put into actual use. No decision has as yet been made whether one of the channels will be used for television, though it is likely that tests will be made in the immediate future. The installation of a short-wave transmitter would be necessary, of course, before any service could be inaugurated in the Birmingham district and this would be a matter for the decision of the Television Advisory Committee in conjunction with the Post Office authorities.

BAIRD TELEVISION

Mr. Harry Clayton has been appointed joint managing director with Mr. John Logie Baird, of Baird Television, Ltd., and Mr. Ian Cremieu-Javal has joined the Board. Both Mr. Clayton and Mr. Cremieu-Javal are directors of the Gaumont-British technical subsidiaries and jointly responsible for their executive control.

Mr. Clayton is vice-chairman of Baird Television and is managing director of British Acoustic Films, a director of Bush Radio and of British Acoustic Marine Equipments.

THE DON LEE (U.S.A.) TRANSMISSIONS

Having experimented for several weeks with night time conditions, the Don Lee transmissions are now to be made at 4 o'clock on Sunday afternoons. The combined experimental broadcasts are put out via KHJ and W6XAO. KHJ broadcasts the sound accompaniment of the vision programme going out simultaneously from W6XAO. Both transmitters are located in the Don Lee Building at 7th and Bixel Streets, Los Angeles. The reason for the change of time is to obtain data regarding daylight transmission.

TELEVISION QUEUE IN KINGSWAY

The first television programme broadcast on Monday, November 2

was demonstrated by the G.E.C. at their offices in Kingsway. So many members of the public wished to see the demonstration that some time before 3 p.m., when the broadcast began a large queue stretched down Kingsway. Public demonstrations are being given daily (at 3 and 9 p.m.) at the G.E.C. offices until further notice.

TELEVISION PUBLIC ADDRESS

The value of television in conjunction with public address was shown during the Motor Show at Olympia. The occasion was the television broadcast by Sir Malcolm Campbell of a description of each of twelve cars selected by the Society of Motor Manufacturers and Traders and took place in the Exhibitors' Club. Four Marconiphone "701" television receivers were installed to convey to a selected audience Sir Malcolm's gestures and remarks. Altogether about 120 people witnessed the reception, each of whom saw everything perfectly. This is the largest number of persons ever to witness a regular television programme.

TELEVISION IN RUSSIA

Regular television transmissions organised by the Azerbaijan are being made in Baku. Demonstrations of reception are being made in a specially equipped studio. The broadcasts include such items as plastic dances, scenes from operas, news reels and readings by well-known writers. No information regarding the system used or the definition is available.

NEW S.W. REGULATIONS IN INDIA

Any short-wave amateur could, until just recently, obtain a transmitting licence in India on request without any technical examination or morse code test. This unfortunately allowed quite a number of non-technical operators to build or buy transmitting equipment without the specialised knowledge required. Now at the request of the majority of amateurs, stringent regulations have been put into force, so that before a licence is granted, several tests have to be undergone. Every intending operator must be able to pass a morse code test of 16 words per minute in conjunction with an examination covering radio theory, law and operating procedure.

AND MORE REFLECTIONS

AMATEUR RADIO IN PORTUGAL

Until further notice all amateur transmitting has been suspended in Portugal. Listening on short-waves is still permitted, but unless a station is actually being used for Government work, no transmitting is allowed. No reasons are given for this ban, but it is suggested that the better equipped amateur stations are temporarily to be taken over by the Government.

A similar ban still applies in Jugoslavia although it is not strictly enforced, but all the same, any amateur discovered using transmitting apparatus can, according to the rules and regulations, be shot. That, of course, is in theory.

SOCCKER TELEVISION

Some idea as to the usefulness of the electron camera can be obtained from the recent broadcast of a football match from Berlin. The international match between Germany and Italy was televised and transmitted through the station at Wizleben, near Berlin. Viewers were able to follow the whole match quite easily for results were claimed to be excellent.

ENTERTAINMENT TAX ON TELEVISION

The Performing Rights Society are claiming fees from owners of television apparatus used for public entertainment. Restaurants and the railway companies have already been approached, and as much as 20 guineas is being claimed from one particular restaurant. This sort of thing may tend to hold up television development if fees are to be required from small dealers staging demonstrations.

INCREASED RANGE ON 5 METRES

The television transmissions seem to be doing a lot of good to the amateurs interested in ultra short-wave reception. It has been found that simple directional arrays with reflectors increase signal strength as much as 50 per cent. These arrays, although not cut to length for 5 metres, are being used on the amateur band with great success. If further progress is made in this manner there is every possibility that 5-metre signals could be used to cover the whole country.

RECEPTION OF TELEVISION SOUND SIGNALS

Many listeners have built simple 1- and 2-valve receivers to pick-up the

television sound signals and report good results from well outside the official service area.

A listener in a basement flat in Gravesend reports loudspeaker reception with a 4-valve super-regenerative set coupled to an aerial 3 ft. long. Reception was obtained at Thorpe with a 2-valve set on a standard 66 ft. aerial.

A radio dealer in Clacton coupled a standard 1-valve super-het converter to a broadcast set and picked up the signals at great strength. Many amateurs using conventional 5-metre 2-valve super-regenerative sets with additional tuning capacity to increase the tuning range to 7/8 metres have heard the signals as far away as Ely, Bedford, Brighton and Hitchin. In many cases, however, a directional aerial was used.

THE SOUTH AFRICAN EXHIBITION

It seems to be getting quite a habit for short-waves to be used in collaboration with events of international importance. The South African Exhibition in Johannesburg is to relay a series of special programmes from the Exhibition to all parts of the world. The idea apparently is to bring before the world the value of South African products, so although direct advertising by radio in South Africa is not allowed, the Government seems to have found a simple way of advertising indirectly.

THE KING AND TELEVISION

Striking proof of the progress made in television is the announcement that television receivers are being installed at Buckingham Palace and Fort Belvedere. In view of the definite entertainment value now given by a modern television receiver, the King has decided to present at Christmas an additional television receiver to the servants at Buckingham Palace.

AMERICAN TELEVISION PROGRESS

America's answer to British television progress is the erection of four transmitters for public service work to be ready in 1937. Two transmitters are being built in New York, one in Philadelphia, and one in Hollywood. According to Mr. Philo T. Farnsworth 441 line systems will be used as compared with 240 and 405

lines in this country. No explanation is given as to how the New York stations will overcome the very serious attenuation of ultra short-wave television signals by the steel-built sky-scrapers, which has always presented a problem to American television engineers.

A TRAVELLING TELEVISION STATION

In view of the success of the Marconi-E.M.I. television system at the Alexandra Palace, the B.B.C. has placed an order with Marconi-E.M.I. for a travelling transmitting station equipped with Emitron cameras suitable for picking up direct scenes of both outdoor and indoor events.

This travelling station should greatly increase the scope and interest in the present programmes. According to Marconi-E.M.I., their Alexandra Palace station has more than fulfilled the contract specification.

"Television, A Guide for the Amateur," by Sydney A. Moseley and Herbert McKay, published by the Oxford University Press price 5s. net. This latest production of the University Press strikes a new note in television text books for it deals most completely with the fundamental principles of modern high-definition television in such a way that the man in the street, without technical training, can gain a very good idea as to how his new television receiver will work.

There are 12 chapters plus a section of television terms. These chapters include electron scanning and the Iconoscope, the electron image camera, light modulation, the cathode-ray tube, the modern cathode-ray receiver and a description of Baird and Marconi-E.M.I. television transmitters.

The book is very profusely illustrated with line drawings and no less than 31 plates, which are mainly full page. This book of 144 pages really does give in a concise form all the details needed by the average television enthusiast, looker-in, or constructor. The main defects with so many television manuals is the inclusion of too much data regarding out-of-date mechanical systems, but in this work, although a chapter is devoted to mechanical scanning, no references are made to old disc systems.

A NEW PHOTO-ELECTRIC ELEMENT

Details of a unit for the direct conversion of light into electrical energy.

THE Tungram Electric Lamp Works, Ltd., have produced a photo-electric element of the boundary layer type which possesses the property of delivering continuous electric current on being subjected to light and similar radiation. This type of element directly converts radiant energy into electrical energy without requiring any auxiliary source of power as is the case with the photo-electric cell and the ordinary selenium cell.

The Tungram light element consists of a metal disc upon which is

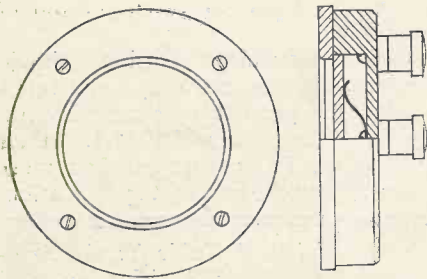

Fig. 1.—Elevation and part section of the Tungram light element.

deposited a layer of light-sensitive selenium, the layer being coated on its outer surface with an extremely thin transparent metal deposit.

The metal disc, and the metal surface coating with its metal ring which surrounds it, constitute the two poles of the light element which are connected to two terminals on the rear side of the housing.

These elements are produced in two sizes. Type S44 consists of a circular

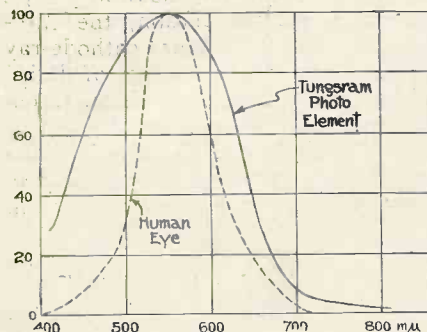

Fig. 2.—Output curve of type S44 photo-element when illuminated by 400 lux.

metal baseplate of 44 mm. diameter, and has useful working surface of 36 mm. diameter, i.e., 10 sq. c.m.

area (see Fig. 1). This type is particularly suitable for use as a photometer (Luxmeter) and are variable with or without external housing.

Type S244 is oblong and measures 22 x 44 mm.; its working area is 36.5 x 16 mm. or 5.8 sq. c.m. This latter type is chiefly intended for photographic exposure meters, and pocket photometers.

When using elements for objective photometry, it is of the greatest importance that the colour sensitivity curve of the device corresponds to that of the human eye. The close approximation of the Tungram light element to that of the human eye is shown in Fig. 2

The approximation of the two curves is quite sufficient when measuring artificial illumination of the type obtained from vacuum or gas-filled lamps; the figures obtained are practically independent of colour sensitivity. If a greater accuracy is required, it is possible to improve the curve of the photo-element considerably, by interposing light filters.

The curves can be made to almost coincide, by using liquid filters consisting of a 0.24 per cent. solution of potassium bichromate ($K_2Cr_2O_7$) and a 10 per cent. solution of copper sulphate ($CuSO_4$). Photometry of even highly coloured light sources (sodium, neon, mercury vapour, etc.) is possible with comparable accuracy to subjective measurements when using the above filter combination.

Photo-voltage and photo-current are shown as ordinates in Fig. 3 with reference to illumination. The open circuit voltage or e.m.f. (shown in Fig. 3 as a dotted line) rises rapidly at first, up to about 100 lux, then rises more slowly and achieves the very high value of .4 volt at 1,000 lux.

The photo-current is approximately .5 ma. per lux, and increases proportionately to illumination intensity with medium illumination, linearity being more accurate when the load resistance is small compared to the cell resistance.

In Fig. 3 curves are given of photo-current dependent on illumination for 0, 50 and 500 ohms load-resistance (galvanometer resistance). In view of the high resistance of the cell, the divergence from strict linearity, even

at 500 ohms load resistance, is very small. However, if better linearity is required, a galvanometer resistance of only a few hundred ohms is recommended. On the other hand, if it is desired to obtain optimum output from the cell, the external load should equal the internal resistance.

From Fig. 4, it will be seen how the output in micro-watts varies with external load resistance at a constant

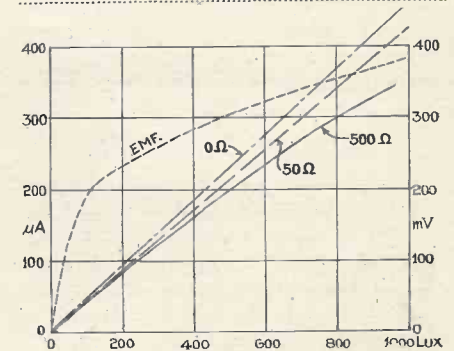

Fig. 3.—Curves showing voltage and current with reference to illumination.

illumination (of 400 lux). The maximum is at 1,400 ohms, thus, at this illumination, the cell resistance has still the high value of 1,400 ohms, and the output has an appreciable value of 27 micro-watts. (In order to properly appreciate this power output, it should be mentioned that the motor of a D.C. ampere-hour counter requires approximately 4-5 micro-watts to move it; actually, it is quite possible to keep such a counter motor in continuous motion with a single photo-element suitably illuminated, despite the fact that the matching of

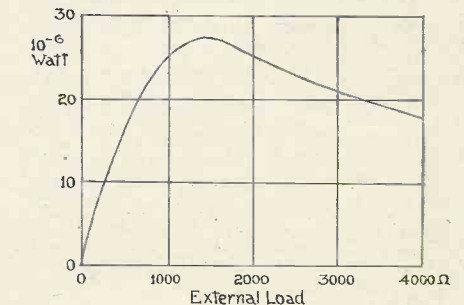

Fig. 4.—Curve showing how output varies with load resistance

such a motor to the cell is a bad one, as the internal resistance of these motors is of the order of 50-60 ohms.

A Buyer's Guide TO Television Receivers

The information given below provides a complete guide to the television receivers which are on the market and available to the public. Omissions in the information indicate that at the time of going to press the required information was not available.

MAKER'S NAME : Baird Television, Ltd., Greener House, 66, Haymarket, London, S.W.1, in conjunction with Bush Radio Ltd., Chiswick, W.4, the latter firm supplying the sets through specially appointed dealers.

MODEL : T5.

PRICE : 85 guineas.

BRIEF SPECIFICATION : Suitable for reception of Baird 240- or E.M.I. 405-line pictures. Twenty valves are employed which include two rectifiers.

POWER SUPPLY : 200-250 volts A.C. The consumption is 240 watts. Instrument can be used on D.C. mains in conjunction with a suitable D.C. to A.C. converter.

DELIVERY : Immediate.

MAKER'S NAME : A. C. Cossor, Ltd., Cossor Works, 22, Highbury Grove, N.5.

MODEL : 137T.

PRICE : 105 guineas.



The Baird, model T5.

No alteration to the instrument need be made to receive 240- or 405-line pictures other than the manipulation of a single switch. The receiver is fitted with six controls, these being Picture Focus, Sound Volume, Picture Brightness, Vision Control, Contrast, Tuning. Detail Control.

PICTURE SIZE : 12 ins. by 9 ins.

CABINET : Vertical console 23 ins. wide 43 ins. high and 19 ins. deep, with the picture produced on a mirror inclined at an angle of 45 degrees to the cathode-ray tube which is vertically mounted beneath a safety glass window.

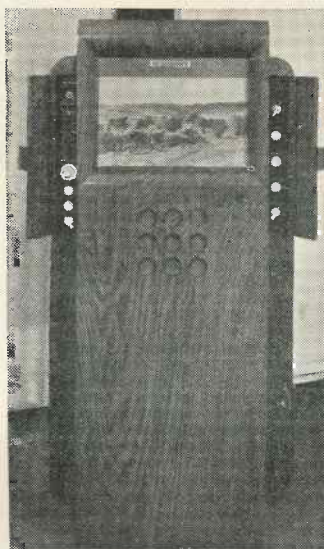

The Scophony Receiver.

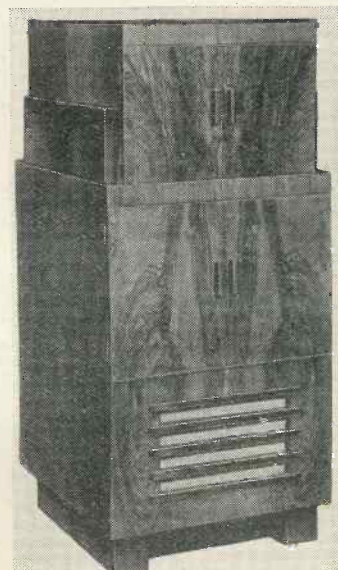

The Cossor, model 137T

BRIEF SPECIFICATION : Suitable for reception of both Baird and E.M.I. systems with simultaneous reception of sound and vision or independent reception of the sound programme without vision. The complete receiver is made up of three chassis, being Tube and Time Base, Sound and Vision receivers, Power Packs and Loudspeaker. Provision has also been made for the use of a gramophone pick-up. A super-het receiver is used on medium and long wavelengths.

WAVE RANGE : 200 to 550, 800 to 2,000.

PICTURE SIZE : 10 ins. by 7 $\frac{3}{4}$ ins. Black and white image. The picture is viewed directly on the end of the cathode-ray tube which is horizontal.

CABINET : Vertical console.

POWER SUPPLY : 200-240 volts 50-cycle A.C. mains. On D.C., a D.C. to A.C. converter is required.

DELIVERY : Immediate.

Ferranti and G.E.C. Receivers

MAKER'S NAME : A. C. Cossor, Ltd., Cossor Works, 22, Highbury Grove, N.5.

MODEL : 237T.

PRICE : 120 guineas.

BRIEF SPECIFICATION : As for the 137T, but includes an additional section with an automatic record changer and gramophone pick-up. A super-het receiver is used on medium and long waves.

WAVE RANGE : 200 to 550, 800 to 2000.

PICTURE SIZE : 10 ins. by 7 $\frac{3}{4}$ ins. Black and white image. The picture is viewed directly on the end of the cathode-ray tube.

CABINET : Vertical console.

POWER SUPPLY : 200-240 volts, 50-cycle A.C. mains. When used on D.C., a D.C. to A.C. converter is required.

DELIVERY : Immediate.

MAKER'S NAME : Ferranti, Ltd., Moston, Manchester, 10.

MODEL : Television sound and vision.

PRICE : 105 gns.

BRIEF SPECIFICATION : This instrument is similar to the previous model as regards reception of television. It includes, however, additional equipment for reception of short, medium and long wave programmes. A 14-in. tube is fitted as standard.

WAVE RANGE : Television sound and vision frequencies plus short, medium, and long wavelengths.

PICTURE SIZE : 10 ins. by 8 ins. viewed directly from the face of the tube, which is mounted horizontally.

CABINET : Console type but of special design.

POWER SUPPLY : 200-250 volts 50-cycle A.C., or from D.C. by means of a suitable rotary converter.

DELIVERY :

MAKER'S NAME : The General Electric Co., Ltd., Magnet House, Kingsway, W.C.2.

MODEL : BT3701.

PRICE : 95 guineas.

BRIEF SPECIFICATION : This is a high sensitivity 23-valve instrument employing a 12-in. cathode-ray tube and is suitable for reception of sound and

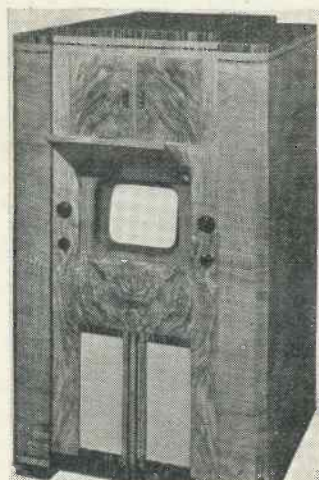

The G.E.C. model BT3702.

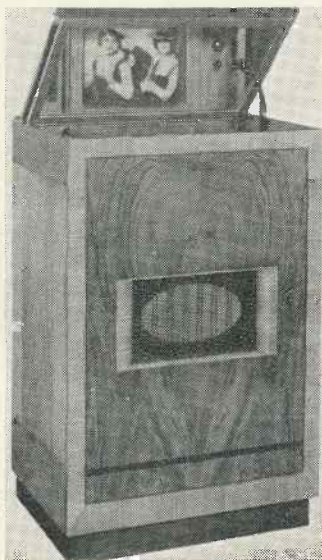

H.M.V., Model 901.



The Marconiphone Model 701.

BRIEF SPECIFICATION : 19 valves are used in this instrument which is suitable for the reception of E.M.I. or Baird television programmes. A feature of interest is the use of a cathode ray tube that is focused magnetically.

WAVE RANGE : Television sound and picture frequencies only.

PICTURE SIZE : 10 ins. by 8 ins. viewed directly from the face of the tube which is mounted horizontally

CABINET : Of the conventional console type.

POWER SUPPLY : 200-250 volts 50-cycle A.C., or from D.C. supply by means of a rotary converter.

DELIVERY :

MAKER'S NAME : Ferranti, Ltd., Moston, Manchester, 10.

MODEL : Television sound and vision and all-wave.

PRICE : 115 guineas.

vision on either 405- or 240-line vision systems. It consists of five units, these being Sound and Vision Amplifier, Double Time Base, Power Pack Cathode-ray Tube and Loudspeaker.

WAVE RANGE : Television sound and vision channels only.

PICTURE SIZE : 9 ins. by 7 ins. Viewed directly from the end of the cathode-ray tube, which is mounted almost horizontally.

CABINET : 39 $\frac{1}{2}$ ins. high, 24 ins. wide, 26 $\frac{1}{2}$ ins. deep.

POWER SUPPLY : A.C. mains 190-250 volts, 40-100 cycles. In conjunction with a D.C. to A.C. converter with a D.C. supply.

DELIVERY :] Immediate.

MAKER'S NAME : The General Electric Co., Ltd., Magnet House, Kingsway, W.C.2.

MODEL : BT3702.

H.M.V., Marconiphone and Pye

PRICE : 120 guineas.**BRIEF SPECIFICATION** : A de-luxe receiver in which provision has been made for reception of short, medium, and long wavelengths, in addition to television sound and vision transmissions. The instrument is suitable for reception of 405- or 240-line systems.**WAVE RANGE** : Television sound and vision channels and short, medium, and long wavelengths.**PICTURE SIZE** : 9 ins. by 7 ins. Viewed directly from the face of the 12-in. tube, which is mounted almost horizontally.**CABINET** : Height 53 ins., width 30½ ins., depth 28½ ins.**POWER SUPPLY** : 190-250 volts, 40-100 cycles. A.C. mains. If used on D.C. supply, a D.C. to A.C. converter must be used.**DELIVERY** : Immediate.**MAKER'S NAME** : "His Master's Voice," 98, Clerkenwell Road, E.C.1.**MODEL** : 901.**PRICE** : 95 guineas.**BRIEF SPECIFICATION** : 22-valve instrument suitable for reception of Marconi-E.M.I. 405-line system or Baird 240-line transmissions. A 6-valve tuned R.F. receiver is pre-set for vision, while a 4-valve super-het. is used for sound.

A 12-in. Cathode-Ray tube gives a picture 10 ins. by 8 ins.

WAVE RANGE : Sound and vision channels only.**PICTURE SIZE** : 10 ins. by 8 ins. viewed in a mirror mounted at an angle of 45 degrees to a vertically mounted tube.**CABINET** : Figured Walnut.**POWER SUPPLY** : 200-250 volts, 50-60 cycles, A.C., or from D.C. mains by means of a rotary converter.**DELIVERY** : Immediate.**MAKER'S NAME** : "His Master's Voice," 98, Clerkenwell Road, E.C.1.**MODEL** : 900.**PRICE** : 120 guineas.**BRIEF SPECIFICATION** : Suitable for reception of Marconi-E.M.I. 405-line interlaced system or 240-line Baird transmission. On the vision side it is similar to the model 901, but in addition is suitable for reception of normal short-, medium-, and long-wave stations. Twenty-three valves are used.**WAVE RANGE** : 7-16, 16.7-51, 46-140, 185-560, 750-2,000.**PICTURE SIZE** : 10 ins. by 8 ins. viewed from a mirror mounted at an angle of 45 degrees to a vertically-mounted tube.**CABINET** : Figured Walnut.**POWER SUPPLY** : 200-250 volts, 50-60 cycles, A.C., or from D.C. mains by means of a rotary converter.**DELIVERY** : Immediate.**MAKER'S NAME** : The Marconiphone Co., Ltd., 210, Tottenham Court Road, W.1.**MODEL** : 702.**PRICE** : 95 guineas.**BRIEF SPECIFICATION** : This instrument is suitable for reception of Marconi-E.M.I. 405-line system, or 240-line Baird transmissions. It is made up of five units, these being Emiscope cathode-ray tube, 4-valve

super-het, sound receiver, a 6-valve tuned R.F. pre-set vision receiver, synchronising equipment, and power packs. A loud-speaker of the energised type gives an output of 3 watts.

WAVE RANGE : Television sound and vision channels only.**PICTURE SIZE** : 9½ ins. by 8 ins., viewed in a 45° mirror in the cabinet lid.**CABINET** : Height 37¾ ins., width 24¼ ins., depth 16¾ ins.**POWER SUPPLY** : 200-250 volts, 50 cycles A.C. Consumption, 230 watts. If used on D.C. mains a D.C. to A.C. converter is required.**DELIVERY** : Immediate.**MAKER'S NAME** : The Marconiphone Co., Ltd., 210, Tottenham Court Road, W.1.**MODEL** : 701.**PRICE** : 120 guineas.**BRIEF SPECIFICATION** : This receiver is suitable for 405-line Marconi-E.M.I. transmissions or 240-line Baird transmissions. It consists of five units, these being the Emiscope cathode-ray tube, All-wave Sound Receiver, Synchronising Equipment, Power packs, and a pre-set 6-valve tuned radio-frequency vision receiver.**WAVE RANGE** : 6.67 metres, 16.7-53, 46-140, 185-560, 750-2,250 metres.**PICTURE SIZE** : 10 ins. by 8 ins. Viewed via a large lens from a mirror mounted inside the cabinet at an angle of 45 degrees to the end of the tube, which is mounted vertically. A 12-in. tube is used and the picture is enlarged by means of a low-power lens.**CABINET** : Height 46¼ ins., width 37½ ins., depth 20½ ins.**POWER SUPPLY** : 200-250 volts, 50-cycle A.C. Consumption, 260 watts. If used on D.C. mains, a D.C. to A.C. converter is required.**DELIVERY** :**MAKER'S NAME** : Pye Radio, Ltd., Africa House, Kingsway, W.C.2.**MODEL** : 4201.**PRICE** : 95 guineas.**BRIEF SPECIFICATION** : This instrument is for reception of television sound and vision transmissions and embodies receivers that are semi pre-set to the correct wavelength. The sound receiver is of the high-fidelity type with a response from 50 to 15,000 cycles. It is suitable for 405- or 240-lines**WAVE RANGE** : Television sound and vision channels only.**PICTURE SIZE** : 10 ins. by 8 ins.**CABINET** : An upright console. Picture is viewed directly from the end of the cathode-ray tube, which is horizontal.**POWER SUPPLY** : A.C. Mains.**DELIVERY** : Immediate.**MAKER'S NAME** : Pye Radio, Ltd., Africa House, Kingsway, W.C.2.**MODEL** : 4200.**PRICE** : 135 Guineas.**BRIEF SPECIFICATION** : The vision and sound channels are similar to the 4201, but embodies additional features such as an all-wave sound receiver and automatic record-changer.**WAVE RANGE** : Television sound and vision channels, plus 17-52, 200-550 and 900-2,000 metres.

THE TELEVISION ENGINEER

FORMATION OF ELECTRON LENSES BY MEANS OF RESISTANCE SPIRALS*

By Manfred von Ardenne

An electrostatic electron lens system is described in which the potential rise along the axis is influenced by changing the pitch of a high resistance spiral introduced into the interior of an isolating cylinder.

IN order to determine the properties of electron lenses, a knowledge of the potential variation along the axis is of great importance. In a work published lately¹ a suitable potential gradient along the axis was theoretically determined for the case of a spherically corrected weak single lens. In the following article a method is briefly described which is technically relatively easy to put into practice in order to achieve, with the help of resistance spirals of modified height of ascent, a previously deter-

mined potential gradient along the axis. Suitable potential gradients may be obtained with the electronic lens proposed by Knoll,² composed of individual parts which can be separately controlled. The potential to be associated with the individual ring electrodes is empirically ascertained by measurements on the three-dimensional model in an electrolytic trough. The practical execution of this kind of electronic lens in the vacuum tube appears to be sufficiently simple so long as the number of rings remain small. By employing a resis-

tance coil with many windings (order of magnitude 20 and more) and varied height of ascent, the same problem may be solved and, in addition, a finely sub-divided potential course may be achieved relatively easily on the electrode cylinder. The production of the resistance layer in spiral form has an advantage over the standard tapping method in that the required resistance values (order of magnitude 1 to 10 MΩ) are easily attainable. With suitable adjustment of the marker it is possible to describe remarkably even resistance bands of $\frac{1}{4}$ to $\frac{1}{2}$ mm. in breadth on the inner wall of glass cylinders. In the case of a glass cylinder revolving with constant speed during preparation, the pitch of the spiral is controlled by regulation of the pivot impulse for the beam. With an electrode cylinder diameter of 5 cm. the pitch can, in practice, be varied in the relationship of about 1:10 without its becoming too great in comparison with the radius of the electrode cylinder. The possibilities for variation given here are insufficient for most problems set by electron-optical systems. To ascertain the required distribution of the pitch the arrangement in the electrolytic trough with ring electrodes, can be employed. In this case the ring electrodes are attached to an equally subdivided potential divider, and their mutual intervals, which correspond to the pitch, can be shifted in the electrolytic trough until the desired potential distribution along the axis is obtained.

A simple procedure by which the momentary potential distribution along the axis can be recognised with little loss of time and compared with the desired distribution, is briefly described. A practical example of a resistance spiral with a constant pitch is shown in photograph. The method of preparing resistance spirals of variable pitch and high ohmic capacity was worked out by G. Otterbein.

Specialised Electrical Equipment and Television Unit

A NEW company under the name of Bosch Hall, Ltd., was formed on August 23 of this year with the object of manufacturing special electrical and scientific equipment such as oscillograph recording instruments designed to meet the requirements of particular cases, cardiographs, valve voltmeters handling frequencies up to 2 and 3 megacycles, direct-reading capacity bridges, etc., and in addition, special apparatus for television requirements such as units for laboratory use and for the amateur, including time bases, H.T. supply units, tube potentiometers, intermediate-frequency amplifiers covering a band width up to 2.5 megacycles for television, vision receivers and adaptors for the conversion of broadcast receivers to ultra-short wave use. The firm has also produced a complete television receiving equipment which will be marketed at £85. This employs 20 valves and a 12-in. tube giving a picture 10 ins. by 7 ins. Still another activity is the manufacture of a range of amplifiers for public-address work. This equipment is of sound design and construction and complete installations for public, commercial use and hospitals, etc., will be undertaken. The firm will welcome any opportunity for the design and supply of equipments which are not standard or are of a special nature.

The address of this new and enterprising concern is Ferry Road, Teddington, Middlesex.

Delivery of Television Receivers

Most of the commercial television receivers are now available from stock and usually installation can be made within two or three days. This is particularly the case with Baird, Cossor, G.E.C., H.M.V., Marconi-phone and Pye receivers, and with each of these the purchaser is entirely relieved of installation troubles.

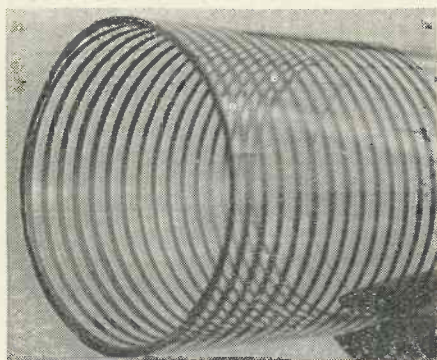

Resistance spiral of high ohmic capacity on the wall of a glass cylinder.

mined potential gradient along the axis.

Suitable potential gradients may be obtained with the electronic lens proposed by Knoll,² composed of individual parts which can be separately controlled. The potential to be associated with the individual ring electrodes is empirically ascertained by measurements on the three-dimensional model in an electrolytic trough. The practical execution of this kind of electronic lens in the vacuum tube appears to be sufficiently simple so long as the number of rings remain small. By employing a resis-

* Archiv fur Elektrotechnik Vol. 30 No. 9 1936

¹ Scherzer: Zeit: f: Physik 101 p. 25 1936

² Knoll: Arch: f: Elek: Vol. 28 No. 13 p. 7 1934

"TELEVISION'S" GUARANTEED CATHODE-RAY RECEIVER— I I

THE CONTROL CHAIN, TUBE AND TIME BASE POWER PACKS AND SOUND RECEIVER

THIS receiver is the first high-definition model ever presented to the amateur constructor. Its construction and satisfactory performance have settled the question which has been debated for some months—whether it would be possible for the amateur to build his own television receiver.

When the design was first considered the particular needs of the amateur were kept in mind so that the construction would be within the ability of the average person who was possessed of a reasonable knowledge of wireless construction.

The complete receiver has been thoroughly tested on the Alexandra Park sound and vision transmissions and gives results comparable with commercially produced receivers.

THE potentiometer chain, of which the theoretical diagram is given on the next page, is assembled on a small sub-baseboard measuring 10 ins. by 4 $\frac{1}{4}$ ins. mounted at the rear of the baseboard which holds the tube.

The values of the resistances and condensers are as follows:—

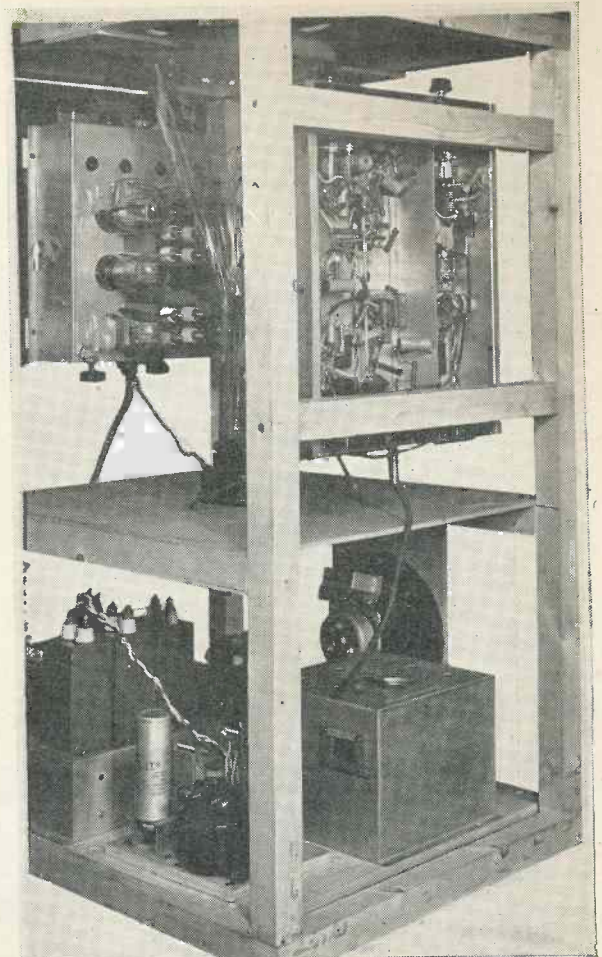

A view of the receiver showing the underside of the sound and vision chassis. The power packs are at the bottom.

- | | |
|------------------------------------|---------------------------|
| R1 2.0 megohms (2 W). | C1 0.5 mfd. 4,000 V. wkg. |
| R2 1.5 megohms | C2 1.0 mfd. 1,500 V. wkg. |
| R3 0.5 megohms | C3 1.0 mfd. 500 V. wkg. |
| R4 1.4 megohm | C4 1.0 mfd. 500 V. wkg. |
| R5 0.4 megohm | C5 0.1 mfd. 4,000 V. wkg. |
| R6 0.1 megohm | |
| R7 0.1 megohm | |
| R8 2.0 megohms ($\frac{1}{2}$ W). | |

The photographs show the method of assembly on the board, the resistance being mounted on a paxolin strip (a Bulgin 5-way group board is very suitable) held on top of the 0.5 mfd. condenser. The resistances R3 and R7, which control the focus and brilliance respectively,

"GUARANTEED"

The television receiver here described and illustrated has been designed and produced by experts working on our behalf for many months.

We guarantee that the picture which this receiver gives compares extremely well with that given by a high-class commercial receiver. It follows that if our readers faithfully follow our instructions in every respect they should produce a thoroughly satisfactory receiver, but certain points must be borne in mind. The reader who has never before had an opportunity of experimenting with a high-definition receiver cannot expect to obtain maximum results until he has acquired some little practical experience. Obviously, he must feel his way, just as he had to feel his way years ago when he started to build broadcast receivers at home.

The precise electrical values of the components is a big factor in success or failure. Those that we specify proved correct in our own receiver, but there is some amount of discrepancy occasionally between the rated values and the actual values of compon-

ents and slight variation of this kind is far more serious in a television receiver than in a sound receiver.

In spite of our great care to give all details accurately, it is difficult in dealing with a mass of tiny detail to prevent the creeping-in of some little omission or error; if anything of this sort has occurred in spite of all we have done to prevent it, we will take the first opportunity of publishing a correction.

Subject to the above and to the employment of sound material and components, our readers may, with every confidence, go ahead and build for themselves a first-class receiver which, within the range of the station will give a good account of the Alexandra Palace transmissions.

We guarantee that our instructions and designs are essentially practical and sound, so much so that we have been able to make an arrangement with a firm of television engineers by which they will, for a moderate fee, bring into working order any receiver which has been built precisely to the instructions here given and with which difficulty is experienced.

COMPLETING THE TIME BASE

are connected to the main chain by long leads and are mounted under the top panel of the cabinet when all is assembled.

The leads in the photograph have been left shorter than will actually be required and simply serve to show the way in which the potentiometers are arranged. The

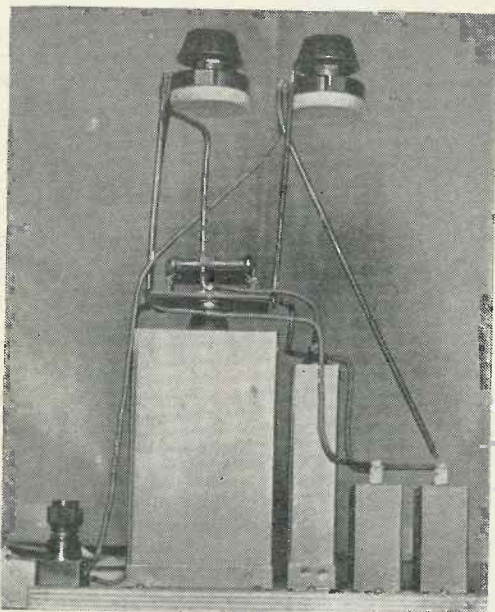

A side view of the resistance chain.

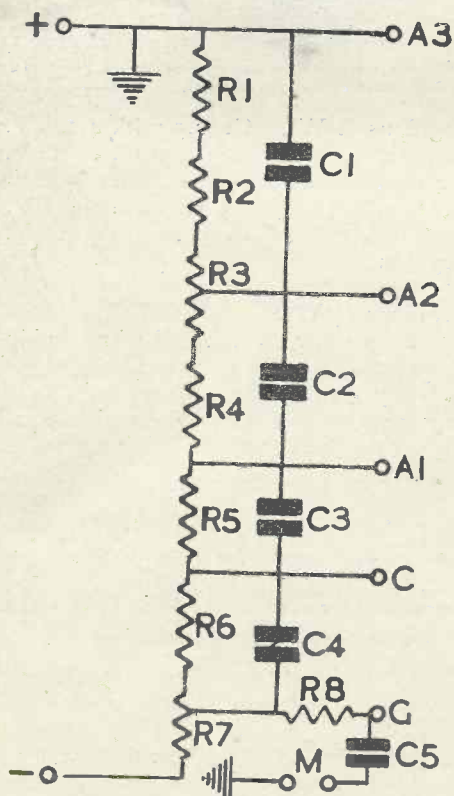

Circuit of H.T. resistance chain for Ediswan Tube.
The values are given in the text.

H.T. supply from the unit is connected to the Belling-Lee terminal block shown on the left of the board. When soldering the resistances in place, be careful that there is no flux left between the ends of the wires which may cause leakage when dust settles on it. The connections to the tube socket may be made after the board has been screwed down on the main baseboard, and these can be taken from the appropriate condenser taps. The connections to the socket of the tube are given. When mounting, the socket should be turned so that the deflector plates are in their correct positions for vertical and horizontal scanning. The convention is to apply the horizontal scan to the "X" plates and the vertical to the "Y" plates. Sufficient slack must be left in the wiring to allow the tube to be turned when final truing up is made.

Modulation

The modulation leads, being at radio frequency, must be as short and neat as possible. Referring to the diagram again, it is seen that the modulation is applied to the terminals marked "M," one of which is earthed to chassis and the other connected through a condenser to the grid contact of the tube. This isolating condenser must be mounted as near the tube socket as possible on the baseboard in such a position that the leads from the receiver can be taken direct to one of its terminals. The resistance R8 is connected in the lead from the potentiometer to the grid of the tube, as near to the socket as possible.

Finishing the Time Base

One or two readers have pointed out that the con-



Another view of the resistance chain. The controls are mounted on the top panel of the framework.

nections to the changeover switch for the two transmissions were not shown in the theoretical diagram of the time base in last month's issue.

CHECKING THE TIME BASE

The omission was made to avoid complicating the diagram as the connection of the switch is that for a standard single-pole two-way. However, to make things clear, the diagram shows the connections to the switch and is numbered to correspond with the numbers on the photograph in last month's issue.

As a number of readers will probably have a stock of fixed resistances, it is pointed out that the high

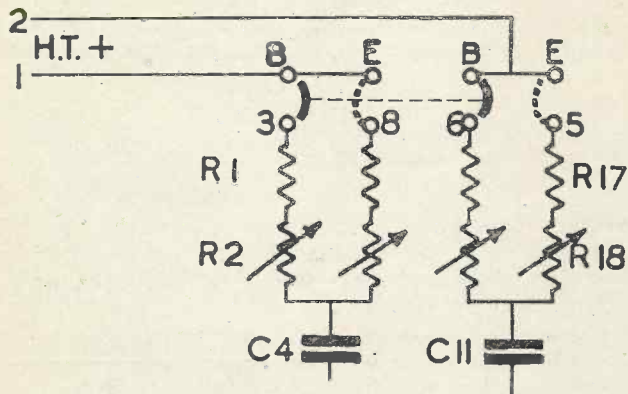

Circuit of changeover switch for Baird (B) and E.M.I. (E) systems. The numbers correspond to the photograph on p. 617 Nov. issue.

values such as $R_1 + R_2$ and $R_{17} + R_{18}$ can be made up of two or three lower values in series if desired. A spare mounting on each of the group boards will accommodate these resistances, and they should be left accessible at the last in case it is necessary to add a small value in series with the existing ones.

The correct operation of the time base depends on such a number of factors that it is impossible to give an approximate setting for the resistances. Variation in sensitivity between individual tubes will alter the overall amplitude and adjustment of this will in turn affect the frequency of the scan. Thus it may happen that the scanning frequency control is at the extreme end of its travel under certain conditions, and in this case it is preferable to alter the value of resistance in series with the variable portion to have sufficient adjustment in hand. The values given, however, are average for the type of tube used and in the majority of cases will cover both scanning frequencies satisfactorily.

Referring to the photograph of the time base on p. 617, the condenser nearest the centre of the chassis is that coupling the grid of one paraphase valve to the anode of the other. This is C6 in the theoretical diagram (0.1 mfd.). Its fellow, C13, is at right angles to it on the left of the centre.

Over on the right-hand side of the chassis against the flap are four 0.1 mfd. tubular condensers, two concealed by the ones above. These are C5, C7, C12, and C14, the feeds to the deflector plates. In front of the lower pair on the right-hand side are the charging condensers C3 and C4, also mounted one above the other. The remaining condensers, excluding the electrolytic, are C11 and C10, on the left-hand side of the chassis, of which the end of one can be seen going to the grid of the first AC/P.

The final wiring of the time base is done by fitting

the line frequency resistance on an insulated bracket over the switches. This is shown in the photograph (see p. 646 of last month's issue, line 16). The leads from the synchronising output cannot be connected until the receiver chassis is complete, but the absence of these will not affect the first check of the time base.

Preliminary Check

The testing of the scanning cannot be done without the tube and H.T. supply, but the time base can be usefully checked before fitting to make sure that nothing is missing.

In testing this and other cathode-ray tube circuits an electrostatic voltmeter is invaluable, but if this is not available, a milliammeter should be connected in each of the valve anode circuits in turn to make sure that they are receiving current. On switching on the time base supply unit the heaters should glow in all the valves and when the H.T. comes on a few seconds later a faint glow should appear in the anode space in the thyratrons. It should be possible to hear the line frequency thyratron and the note should alter as the velocity control is turned. It should also be affected by

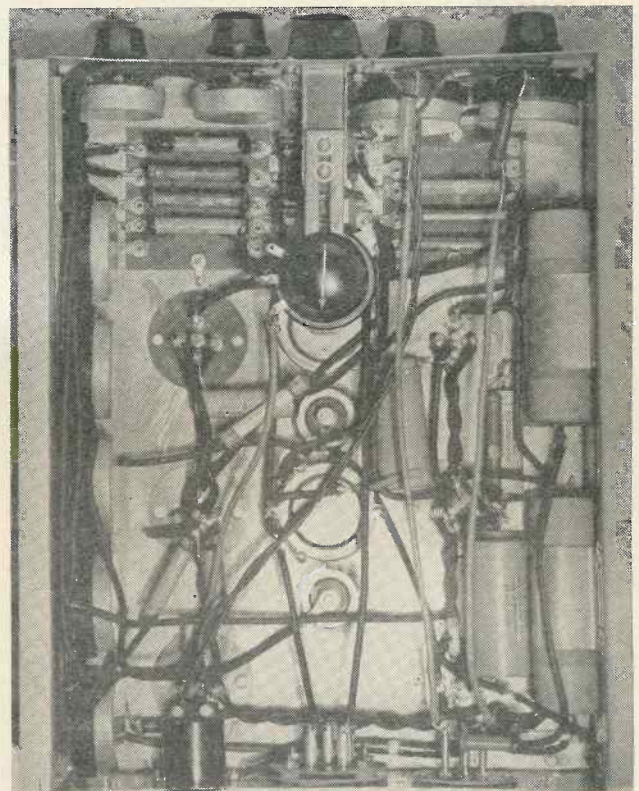

Underside view of time base chassis.

the bias control of the thyratron. The time base should be left running for a considerable time to make sure that no local heating develops due to accidental contact, and it can then be switched off and fixed to the battens.

Correction.—In the diagram of the time base chassis in last month's issue (p. 618) there was a discrepancy in the numbering of the holes. Holes 17 and 18 are for the AC/P's, and 15 and 16 for the electrolytic con-

POWER PACK FOR CATHODE-RAY TUBE

densers. The complete chassis as supplied has two further holes midway between 12 and 17 and 13 and 18 for the paraphase tapping resistances if required, although as pointed out in the text these are not always essential. The complete chassis is available from Burne Jones.

The Eddystone Microdenser, C12, specified in the list of parts as type 900/140, should have been given as 900/40, and these figures should be given when ordering.

Power Pack for Cathode-ray Tube

IN the May issue there was published a complete description of a 3,500-volt unit for exciting a cathode-ray tube. This unit utilised a high vacuum rectifier which allowed the filament and anode voltage to be switched together. Slight changes have been made in this unit, but they will not prevent those of our readers who built the one described then from employing it in conjunction with the "Guaranteed Receiver."

With the control panel used in the receiver a maximum of 4,000 volts D.C. is provided. This produces bright pictures and the time base is able to sweep the full picture area. This point is mentioned as the deflection sensitivity of the cathode-ray tube is a function of the final anode voltage applied.

No provision is made for the heating of the tube cathode heater as this has been taken care of in the

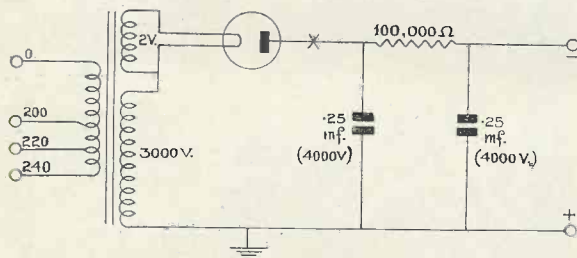

Circuit of cathode-ray tube power pack

time base power pack. The scheme of connection to the A.C. mains is such that the tube cathode heater is allowed to come up to temperature before the high voltage is applied.

The complete unit is enclosed inside a metal case so that a measure of protection is provided. However, it must be borne in mind that the voltage is very high and the utmost caution should be exercised both when building it to see that the insulation of connecting leads is good and when using the unit by not making any adjustment with the mains supply connected. There is no danger if these precautions are observed.

If reference is made to the circuit diagram it will be seen that the unit consists of a single-wave rectifier with a .25-mfd. 4,000-volt working reservoir condenser with further smoothing by 100,000 resistance and another .25-mfd. condenser. The positive of the D.C.

is earthed and the unit should not be used with the negative pole earthed.

The actual construction will be found quite easy. All the components are mounted on the shallow metal base which is supplied ready drilled. In the May issue a wooden baseboard was used, but this has been dispensed with by reversing the shallow metal base and mounting the components directly on to it.

The D.C. output is taken from the tops of the final smoothing condensers as opposed to the plug-and-socket arrangement of the unit described in the May issue. Heavily insulated leads should be taken to the ends of the control panel network through the hole in the top of the metal container that surrounds the completed unit.

The mains input is properly fused by using a Belling-Lee connector unit to which the mains tapping on the transformer are wired. The mains cord is taken through the bottom of the shallow base to the delay switch terminals on the time base unit.

Components for Cathode-ray Tube Power Pack.

TRANSFORMER.	SUNDRIES.
1—Mains transformer (London Transformer Products, Ltd.)	1—100,000-ohm, 1-watt resistance (Erie).
CONDENSERS.	1—Chassis and cover (Mervyn).
2—.25-mfd. 4,000-volt working (B.I. Mervyn).	1—5-pin valve holder baseboard type (Bulgin).
	1—Valve (Osram Ur6 or Mullard H.V.R.).

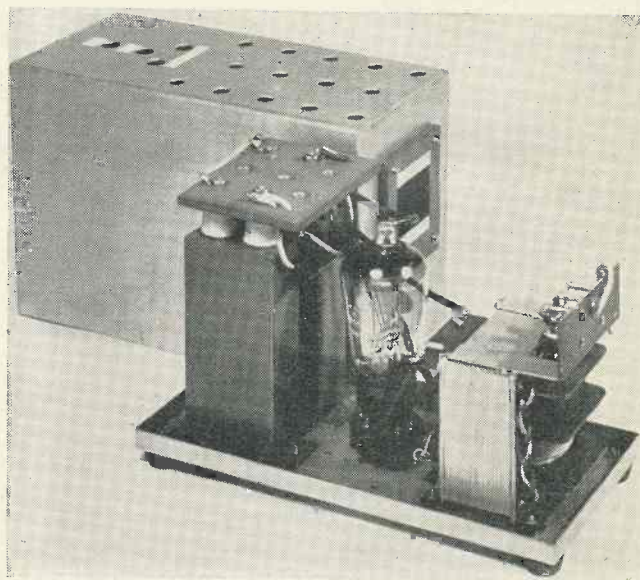

The cathode-ray tube power unit.

Several transformers made by W. Bryan Savage, Ltd., Sound Sales, Ltd., Keston Manufacturing Co., Ltd., and London Transformer Products, Ltd., have been tested and used as described over a period and have been found satisfactory.

The smoothing provided has, under most conditions, proved sufficient, but if hum is experienced it will be a simple matter to add more across the control panel network.

THE TIME BASE POWER PACK

The time base power pack provides, in addition to the H.T. and L.T. for the relays and valves, a 2 volt supply for the cathode ray tube and the thermal delay switching for the cathode ray exciter unit.

It is divided into two sections. One is for the actual time base and heater current for the cathode ray tube and the other is to provide the shift voltage to enable the picture to be properly centred on the screen.

This second unit is quite conventional and consists of a mains transformer, rectifier valve with an 8-plus-8 mfd. electrolytic condenser. No smoothing choke is

minimal on the heater transformer. It will be readily seen that if the input voltage on the mains connector is placed either at the 200-volt point or the 240-volt point the voltage across the other transformers will automatically become 220 volts. This is due to the fact that the primary of the heater transformer is acting as an auto-transformer for the others. In this way there is a reduction in cost and fewer leads to sort out and connect.

The circuit diagram shows the proper connections so that the power pack for the tube and shift voltage (which are external) have only to be connected to the

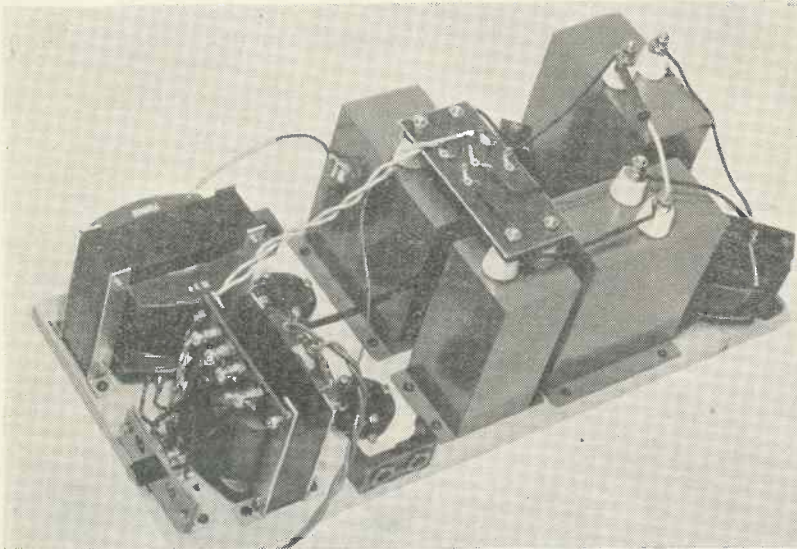

This photograph shows the completely assembled time base power pack.

employed but a $\frac{1}{4}$ -megohm resistance is substituted. There is such a small current draw that the expense of a choke is not warranted. This unit could conveniently be replaced by two small 120-volt H.T. batteries in series as its only purpose is to apply an additional voltage to the deflector plates of the cathode-ray tube for centring the picture. The advantage of using batteries is twofold: it represents a saving in cost and removes the possibility of introducing mains hum to the scanning deflectors.

Delayed Switching

The time base H.T. and heater supply has been designed with a dual mains transformer input so that the heaters (including the cathode-ray tube) are allowed to come up to operating temperature before the H.T. voltage is applied. As soon as the heaters have warmed up the thermal delay switch operates. This switches the mains transformer providing the H.T. to the time base. It also is arranged to switch the cathode-ray exciter unit.

Reference to the circuit diagram given in this issue shows terminals connected to the delay switch. The delay switch operates in the primary circuit of the mains transformers. These transformers are wound for 220 volts only, so that the connection to the mains via the delay switch is taken to the 220-volt ter-

appropriate terminals. (These are black and are on one side of the unit). On the opposite side of the unit are placed the red terminals. They are connected to the tube heater winding so that the current to heat the tube is readily obtainable.

The photograph shows clearly the positions of the various components allowing ample room for connecting up. The current for heaters and the two H.T. + and one H.T. - points are taken through the top of the cover. It will be noticed that the H.T., etc., to the time base is via a plug, the corresponding socket for which appears on the back of the time base chassis. Accordingly the leads from the plug for this must terminate and be anchored inside the power pack.

This is arranged by drilling four holes in a piece of bakelite to correspond with the terminals on the top of the 2-mfd. and first 8-mfd. condenser. This bakelite should be drilled with a further five holes so that the leads can be secured. It is then only necessary to solder the leads in their correct positions inside the power pack. Reference to the photograph shows this clearly.

Notice that the smoothing chokes have been placed in the negative lead. This then places the winding and core at the earth end, so minimising the risk of breakdown. However, if mains hum is experienced it may be reduced by placing them in the positive lead.

Components for TIME BASE POWER PACK

- CHASSIS.**
1—Special metal chassis and cover (Mervyn).
- CONDENSERS, FIXED.**
3—8-mfd. 1,000 volt (B.I.-Mervyn, or T.C.C.)
1—2-mfd. 1,000 volt (B.I.-Mervyn or T.C.C.)
1—8 plus 8-mfd. condenser (B.I.-Mervyn).
- CHOKES, LOW-FREQUENCY.**
2—100 henry 30 M/a (Keston Manufacturing Co.).
- HOLDERS, VALVE.**
3—5-pin type VH10 (Belgin).
- PLUGS, TERMINALS, ETC.**
1—Plug top valve connector type 1,156 (Belling-Lee).
1—Fused voltage change input corrector type 1,088 (Belling-Lee).
2—Terminals type B red, (Belling-Lee).
2—Terminals type B black (Belling-Lee).
2—Terminals blocks type 1,039 (Belling-Lee).
- RESISTANCES, FIXED.**
1—.25 megohm type 1 watt (Erie).
1—2,000 ohm type 1 watt (Erie).
- SUNDRIES.**
Connecting leads, wire and sleeving.
1—Bakelite strip.
- TRANSFORMERS, MAINS.**
1—Filament transformer (Keston).
1—H.T. transformer (Keston).
1—Shift transformer (Keston).
- VALVES.**
1—MU₂ (Mazda).
1—DLS/1 (Mazda).
1—U.U.3. (Mazda).

BUILDING THE SOUND RECEIVER

The mains lead is taken through the bottom of the shallow metal base which will be found very convenient. Care should be taken to see that the leads coming out of the top cover are well protected so that the metal edge of the hole does not cut through the insulation.

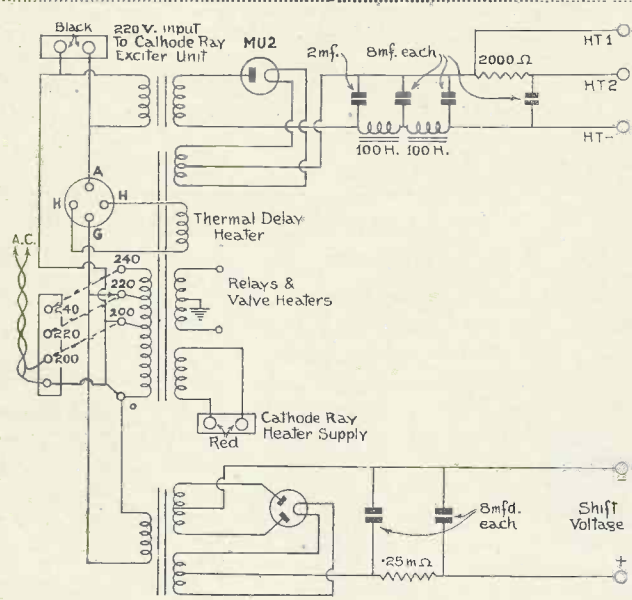

The Sound Receiver

The sound receiver is given complete in this issue and derives its power supply from the combined power pack already described. It comprises a TH4 triode hexode frequency changer feeding into one stage of I.F. amplification on approximately 115 kc. The output is rectified by a WX6 detector unit which is then amplified by one stage employing a Mazda AC2/Pen.

The I.F. transformers are not tuned by trimmers as it is not desired to have extreme selectivity or to have careful layout and wiring, to avoid instability. These untuned transformers together with the load of the Westector, provide a band width capable of taking care of high fidelity sound transmission on the ultra short-wave transmitter.

Where signal strength is very low the sensitivity may be increased by placing a small tuning condenser across one winding of an I.F. transformer: it may be wired directly with stiff wire and need not be mounted on the chassis. Normally this condenser is not required.

The frequency changer follows the design of the vision receiver except that the signal input is not tuned. It is unnecessary to tune this in any way as the coil specified acts as a choke.

The aerial may be any normal type, in fact the ordinary broadcast aerial can be used. Use a crocodile clip and place the aerial directly on to the grid end of the

TIME BASE POWER PACK

By the use of 100-henry smoothing chokes and ample capacity, all traces of hum have been eliminated. The mercury-vapour rectifying valve gives a high current output and enables a satisfactory voltage level to be maintained. A thermal delay switch prevents high voltage being applied to the rectifying valve until the filaments are completely warmed. This thermal delay switch has approximately a one minute time lag. On the right is a photograph showing a plan view of the Time Base Power Pack.

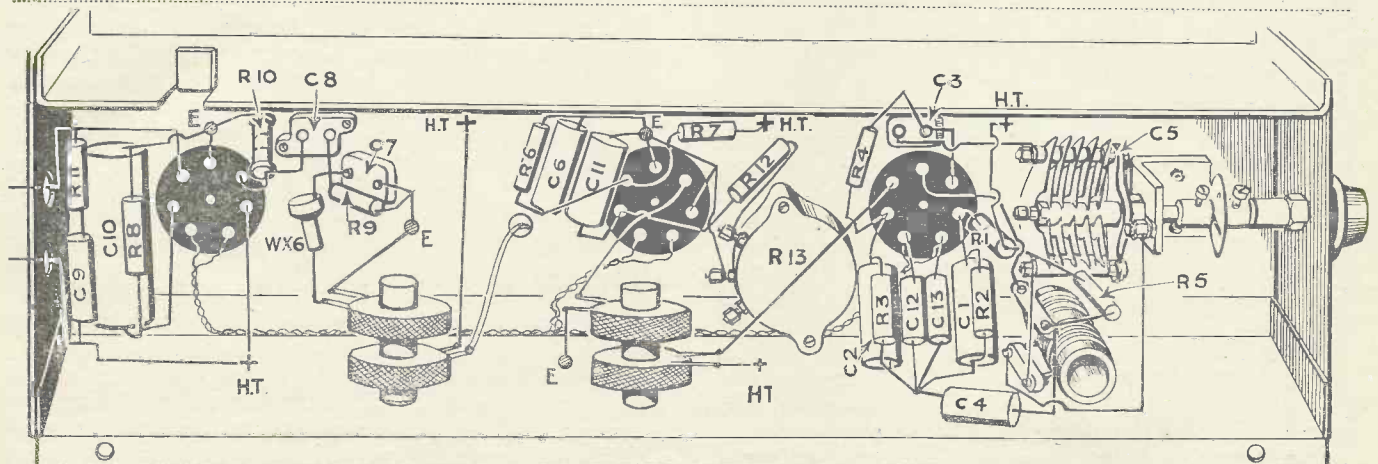
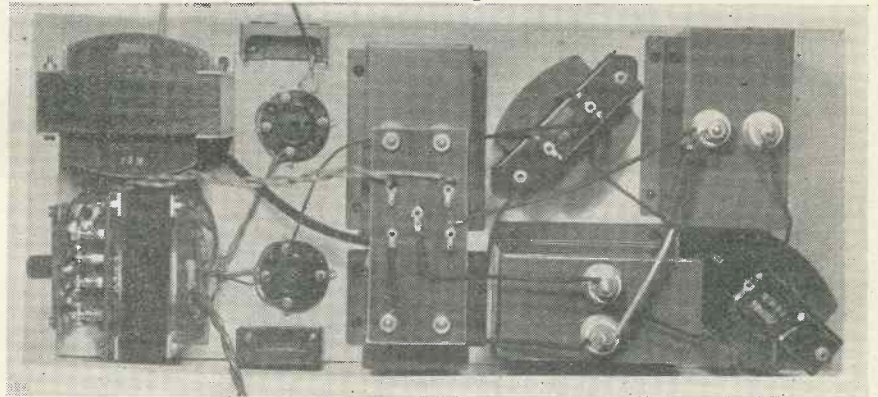
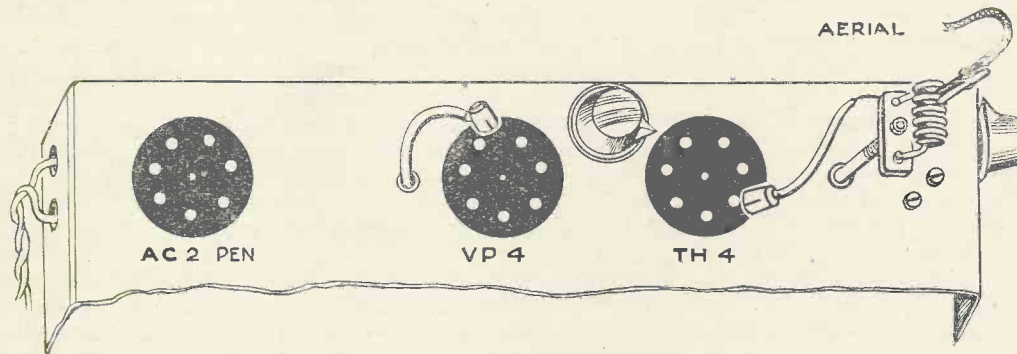

Diagram showing the principal components of the sound receiver and their arrangement on the section of the vision and sound chassis. This drawing shows the underside. Reference should be made to the two drawings on pages 613 and 614 in the November issue.

THE SOUND RECEIVER (Continued)

coil. If the noise level is very high, a reduction of outside noise pick up can be obtained by tapping the aerial down the turns of the grid coil. At short distances from Alexandra Palace it will be found that re-

in the chassis wiring and taken out through the two holes in the back. Notice that a pentode filter has been provided. The resistance used here is of the fixed type but an efficient tone control can be made of this



Drawing showing top of sound receiver section

ception at good strength is obtained on the direct pick up of the grid coil itself.

The wiring and method of mounting the components will be readily seen from the illustrations and will be found quite straightforward.

if made variable and its value increased to 30,000 ohms.

It will be necessary to cut the centre dividing plate of the chassis at approximately the position shown. This is easily carried out with a hacksaw. Make two cuts about 1/2 in. apart and 1/2 in. down: this will leave

An untuned input circuit is used in the Sound Receiver and this method has proved entirely satisfactory. Owing to this, all tuning is carried out by means of a single condenser. The one intermediate frequency circuit gives ample gain owing to the use of a high slope valve and comparatively low frequency I.F. transformers. Speech output is in the order of 3.5 watts, when coupled up to a speaker of the specified type with a load of 7,000 ohms.

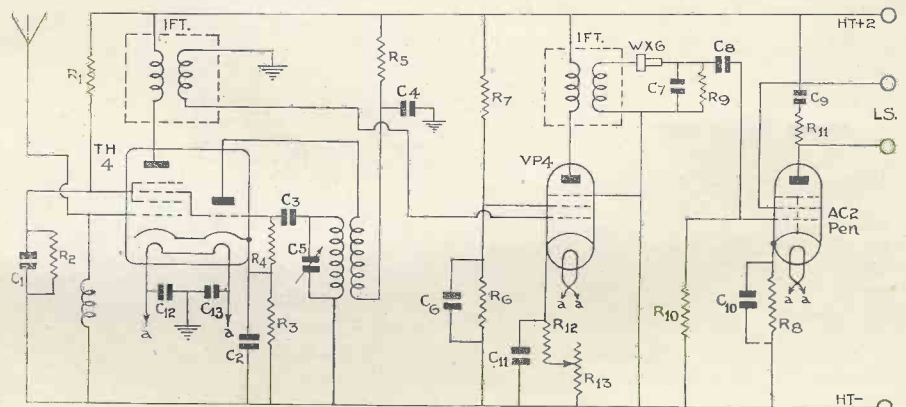

The output leads to the loudspeaker take the form of twisted flex soldered directly on to their correct points

a tongue which is then bent at right angles. The H.T. and L.T. leads to the sound section are taken via this slot and tied to the tongue so formed to secure them.

List of Components for Sound Receiver

1—Westector WX6 (Westinghouse)

RESISTANCES.

- R 1—50,000 1 watt type (Erie)
- R 2—50,000 " "
- R 3—200 " "
- R 4—50,000 " "
- R 5—20,000 " "
- R 6—50,000 " "
- R 7—50,000 " "
- R 8—300 " "
- R 9—100,000 " "
- R10—1/2 megohm " "
- R11—20,000 " "
- R12—100 " "
- R13—1,000 ohm potentiometer Bulgin

CONDENSERS.

- C 1—.1 type PCP1 (Bulgin).
- C 2—.1 type PCP1 (Bulgin).
- C 3—.0001 type M (T.C.C.).
- C 4—.1 type PCP1 (Bulgin)
- C 5—Variable type 900/40 with slow motion head No. 1012 (Eddystone).
- C 6—.1 type PCP1 (Bulgin).
- C 7—.0001 type M (T.C.C.).
- C 8—.01 type 300 (T.C.C.).

- C 9—.01 type 300 (T.C.C.).
- C10—50-mfd. 12-volt working type E.C.3 (Bulgin).
- C11—.1 type PCP1 (Bulgin).
- C12—.01 type 300 (T.C.C.).
- C13—.01 type 300 (T.C.C.).

COILS.

- L1—6 turns bare copper or Eddystone type 1050.
- L2—4 turns bare copper or Eddystone type 1050.
- L3—4 turns bare copper or Eddystone type 1050.

TRANSFORMERS.

- 2—I.F. transformers untuned (Varley BP95).

LOUDSPEAKER.

- 1—W.B. Junior.

SUNDRIES.

- 2—Valve top connectors (Belling & Lee) connecting wire and flex, etc.
- 3—Seven pin-valveholders (Clix).

VALVES.

- 1—T.H.4 (Mullard).
- 1—V.P.4 (Mullard).
- 1—AC2/Pen (Mazda).

When this sound receiver is first switched on and the station tuned in it will be noticed that when passing through the setting of the vision oscillator a beat note is produced. However, when both stations are tuned to their appropriate wavelengths no interference of any kind will be experienced between the two sections.

Next month we shall present a Complete Summary of the Entire Receiver

"How to Operate the Cathode-ray Tube"

(Continued from page 685)

the electron optical system remains constant. In this connection the family of characteristic curves, Fig. 6, showing the variation of the current to the third anode with variation of grid voltage, taken at different values of first anode voltage are of considerable interest. They show, among other things, that, as in the case of a screened grid valve, the available grid base may be controlled by the voltage applied to this electrode.

The Anode

Diaphragm

The focusing anode has a diaphragm, the object of which is to intercept those electrons whose paths are too widely divergent to be brought to a good focus, and this has the effect of minimising the "spherical aberration" effect.

The main electron lens effect in this tube, as stated, takes place between the second and third anodes, and the focal length can be adjusted through a wide range by varying the ratio between the voltages applied to these two electrodes. Since, however, the optimum focal length is fixed by the position of the fluorescent screen, the ratio of the second and third anode voltages is also fixed, and is virtually independent of the magnitude of the applied voltages within the working range. For the Mullard tube in question this ratio is approximately 1 to 5.

The Beam

Outline

Further consideration of the beam outline or the shape of the "beam envelope" as the voltage of the second anode is varied between values above and below the optimum value illustrates still more clearly the analogy between the optical and electron lens effects. Commencing with a constant third anode voltage and a second anode voltage which is several hundred volts too high for correct focus, i.e., with too weak a focusing field, the beam will be found to be divergent. If the second anode voltage is now gradually reduced, the beam will become less and less divergent, finally becoming first a parallel beam, and then more and more convergent until, at the correct value of second anode voltage, it is brought to a focus at the screen. If the second anode voltage is further reduced, that is, the focusing field is made too strong, the focal point will recede from the screen toward the third anode, and at the same time the diameter of the beam at the new focal point will be decreased, much in the same way that very great concentration of the sun's heat rays can be obtained with a burning glass.

Screen

Distance

Now it is obvious that it is desirable to obtain the smallest possible spot size at the screen, and in view of the effect described above, it may be suggested that the distance between the final anode and the screen should be reduced and a higher value of electro-static field be used for focusing. But if this were done, the deflection sensitivity of the tube would be very greatly reduced since, as has been shown in a previous article,

the deflection sensitivity is largely dependent upon the distance between the deflection plates and the screen. In this matter, therefore, as in many others, the tube manufacturer has to design the electrode system as the best possible compromise between the optimum requirements for the individual characteristics.

Before leaving this section of the subject, reference should be made to Fig. 7 which shows above the effects on the electron stream due to the various electrodes, and below the effects upon a light beam due to various optical devices. The paths in the two cases are identical, and it is clear that the first anode may be considered mainly as a diaphragm, the second and third anodes as having the effect of a convex lens, and the deflector plates as acting in a similar way to a prism.

Spot

Size

It has been shown that, due to the fact that the cathode-rays are propagated in straight lines and are amenable to various controls analogous to those which produce changes in the direction of light rays, the beam can be brought to a focus on the fluorescent screen. If the cathode-rays behaved exactly like light, the definition of the image on the screen would be dependent solely upon the accuracy of focusing. But unlike light, the electrons comprising the cathode-ray beam carry negative charges, and therefore mutually repel each other, with the result that there is a tendency of the beam to spread so that the ultimate spot size increases. It will be clear that for a given tube structure the higher the electron content of the beam, that is the greater the beam current, the greater will be the beam diameter at the screen. On the other hand, an increase in beam velocity (governed by the final anode voltage), will decrease the space-charge effect in the beam and thus reduce the "angle of spread."

These facts can be summed up in the statement that for a given value of beam current the focal spot at the screen will tend to become smaller with an increase in final anode voltage, while for a fixed value of anode voltage the spot size increases with an increase in the beam current.

Obtaining Good

Definition

Thus, where a high degree of definition is required, as in television or for making very accurate measurements, a low beam current and high final anode voltage are indicated. On the other hand, it was shown in the previous article that for maximum deflection sensitivity a low final anode voltage is called for. These two sets of conditions are in direct conflict, and when considered in conjunction with the third requirement, namely, adequate screen brightness, present another problem in the art of compromise. For the screen brightness increases with both beam current and final anode voltage, although the anode voltage exercises the greater influence in this connection.

In view of the mutual opposition of the optimum operating conditions for spot size (or definition) and deflection sensitivity, it is necessary to strike a balance depending upon actual requirements, and the maximum screen brightness attainable is then fixed by the conditions demanded to satisfy the first two requirements.

STUDIO & SCREEN

A MONTHLY CAUSERIE on Television Personalities and Topics

by K. P. HUNT
Editor of "Radio Pictorial"

ON with the show! Television programmes of excellent quality are now on the air every day, for, as all readers know, a definite landmark in radio history was made at the beginning of November, when the ceremonial transmissions officially inaugurating the first regular television service were broadcast.

It is sufficient, at this comparatively late date, merely to record that this important debut went off without hitch of any kind, and certainly it provided a convincing demonstration of the high efficiency of the organisation which Gerald Cock, the B.B.C.'s popular Director of Television, has so carefully built up, and of the personal abilities of many members of his staff.

I do not suppose, however, that many of the thousands of "lookers" realised the split-second timing which was necessary for the success of this official first broadcast, so let me begin by giving you a little sidelight which reveals how precisely the individual items had to be dovetailed into the whole.

While Leslie Mitchell, the television announcer, was finishing his introduction given in the Baird spotlight studio, Mr. Norman, chairman of the B.B.C., had begun *about half a minute before* to address the same unseen audience via the Baird intermediate-film system. As readers know, the latter system is not instantaneous television, for a slight time lag occurs between the event and the distant viewer's sight of it on the receiving screen, during which the film is being developed. Matters were so well timed that no interval was apparent, and the change-over from the spotlight studio to the intermediate-film system did not interrupt the continuity of the programme.

I am told that the Baird engineers took quite elaborate precautions against any breakdown and had one of their much-discussed electron cameras trained upon the speakers most of the time, so that in the event

of accident it would be brought into action without delay.

If everything that I have heard recently about this Baird electron camera is correct, its advantages will be many. I was told at Alexandra Palace the other day, however, that there are still some details which need perfecting and this is proceeding rapidly.



Rosalind Wade, brilliant tap dancer of "Dancing Daughters" fame, appeared recently on the television screen.

The Marconi-E.M.I. transmission, which formed the second inaugural programme, was an equally pronounced success.

* * *

Everyone at Alexandra Palace was genuinely pleased to see Sir John Reith, the B.B.C.'s Director-General, at the opening ceremony; but I think many members of the general public were a trifle disappointed that he did not take an active part in the broadcast. His apparent aloofness on this occasion, as on others, tends to give an impression that he is somewhat removed from the great mass of people for whom he is catering—a supposi-

tion, of course, which is entirely wrong—for Sir John has shown a great personal interest in television since its very beginning, and has impressed most people at Alexandra Palace, as at Broadcasting House, with what, for want of a better term, I may call his "sense of humanity."

For instance, I spotted Sir John in the canteen at Ally Pally, mixing freely among some of the lowest paid members of the staff. This canteen is not a large one, but it has a tremendously high ceiling. The thing that struck me most about it was that surely this popular staff restaurant must be the noisiest in London! For some reason every little noise is echoed in a most disconcerting manner. If you tap a spoon upon one of the tables, you hear a greatly magnified echo coming back to you from all directions.

Sir John was there with Major Tryon, the Postmaster-General, John Logie Baird, and numerous other celebrities.

* * *

Gerald Cock has pretty well recovered from his recent illness. The latest member of the staff to be smitten low is "Bumps" Greenbaum, popular conductor of the Television Orchestra. "Bumps" was the hero of an incident a couple of weeks ago when, threatened with severe gastric trouble, he set out for the Palace to conduct the television orchestra for Vaughan Williams' ballet.

But from what I gathered, he practically collapsed in the studio. There were frantic telephone calls to Broadcasting House for Leslie Woodgate, who hurriedly arrived by car and conducted the orchestra for both afternoon and evening performances.

When I visited Alexandra Palace the other day I found that "Bumps" was still off duty, but was told he was considerably better. He was then able to talk and walk, and was making a satisfactory recovery.

SOME OLD FAVOURITES

And now to get away for a moment from the serious note, for it must not be supposed there is no laughter or excitement at Ally Pally.

Here is a true story. The incident happened during a television broadcast the other Saturday by Mr. David Seth-Smith, the well known curator of the Zoological Gardens, London, who, of course, is exceedingly well known to ordinary broadcast listeners as "The Zoo Man." One of the exhibits he brought from the Zoo to show on the television screen was that highly accomplished and talkative bird known to all visitors to the Zoo as "Cocky."

Now it appears that Mr. Gerald Cock "has a way" with animals and birds. They quickly make friends with him, and there seems to be some subtle psychic affinity beyond my power to explain.

On the occasion of Mr. Seth Smith's programme, this clever cockatoo boldly perched upon the D. Tel.'s shoulder. Then, turning its head knowingly towards the great White Chief, shrieked out: "Kiss Cocky! Kiss Cocky!"

Later on, so I was told, the D. Tel. had a friendly old chimpanzee nestling in his arm as affectionately as a baby.

* * *

Mr. D. H. Munro, the Productions Manager at Ally Pally, is still keeping things humming. Now that organisation is more complete, he is finding it possible to take a hand himself in production work, one of his first self-appointed tasks being the Sokolova programme. This was a solo performance by the great dancer, for she was not supported by the usual *corps de ballet*. I dare say many of Sokolova's old television friends were pleased indeed to see her back on the screen.

As we all know, Sokolova was responsible for the first television ballet in the old 30-line days, and for many which succeeded it. What is not so widely known, however, is that Sokolova arranged the dances for numerous other celebrated dancers who graced the television screen during Eustace Robb's regime.

* * *

Writing about the old 30-line reminds me to point out that quite a number of the more distinguished artists who made a hit in the ante-

deluvian era of the science are now scheduled for an appearance under the high-definition system. Laurie Devine, who was known in the old days as the "Television Ballerina," is, I am glad to say, shortly to make an appearance.

This is a wise and generous gesture on the part of Mr. Munro, for there can be little doubt that these popular favourites of yesterday contributed in no small measure by their enthusiasm and painstaking preliminary work to the success of the 30-line programmes and to the development of studio technique, all of which, notwithstanding some statements now made to the contrary, laid the real foundation of present-day practice. Does it not seem only fair that, if their performances can be modified to-day to suit the new requirements, the previous efforts of these pioneers on behalf of television generally should now meet with the reward they merit and an opportunity be given them to demonstrate their talents afresh?

Mr. Munro confided to me that the only reason he has not used them before is that until the regular television service began, it was not fair to put into the programmes any established performers whose reputation might not be enhanced by an appearance under conditions which were purely experimental. Those considerations do not apply now.

* * *

The other producers have had an equally busy time during the month. Cecil Lewis is still mainly engaged upon the development of the O.B. side of the work, and Dallas Bower, Stephen Thomas, and Cecil Madden have all been responsible for some exceedingly creditable transmissions.

Stephen Thomas, I gather, is to be mainly responsible for television ballet productions, and in this direction, of course, his long experience of similar work in all parts of the world will stand him in great stead.

Dallas Bower scored a notable success with his Masked Theatre feature in the middle of the month, when Pamela Watson, Yolande Proctor and Alex Passavant—who are players from the Mask Theatre, Linden Gardens—performed a number of mimes to music, mostly by Stravinsky, which was rendered with great charm by the television orchestra.

I was privileged the other day to spend a most interesting hour watching Dallas Bower rehearsing the first public presentation of "Mr. Pickwick," Albert Coates' new three-act opera, adapted from the "Pickwick Papers," by Charles Dickens.

The stage show itself, which is dedicated to "lovers of Dickens all over the world," was produced last week at the Royal Opera House, Covent Garden, by Vladimir Rosing who, by the way, is father of the talented Val Rosing, formerly a vocalist with Henry Hall and the B.B.C. Dance Orchestra.

Some idea of the activity at Ally Pally will be gleaned when I explain that the morning rehearsal which I witnessed was the only rehearsal for the television programme proper due the same afternoon. The Marconi-E.M.I. studio was an indescribably hectic hive of busy preparations.

One of the Alexandra Palace officials perched me right at the back of the studio, behind the orchestra and well out of everyone's way, but from that vantage point I was able unobtrusively to survey and hear everything that was going on.

Looking over the heads of the orchestra, in the immediate foreground, was the famous Albert Coates himself, composer of the music, who was then making a personal visit to Alexandra Palace to conduct the Television Orchestra.



Albert Coates conducted the Television orchestra when his new opera "Mr. Pickwick" was produced at Alexandra Palace. Here he is seen discussing the score with William Parsons ("Mr. Pickwick")

WATCHING A REHEARSAL



Lisa Minghetti, who featured in "Starlight." This is a reproduction of a painting of her by Philip de Laszlo, the celebrated artist.

Dressed in a very comfortable-looking jacket and wearing a soft collar and bow, this respected veteran of the musical world seemed easily to be the most unperturbed and unexcited person among the fifty or sixty people crammed into the studio.

Out of the corner of my eye, so to speak, I watched Coates conducting with that unconscious aplomb which proclaims the true master. But even

he became a wee bit worried about the right moments to come in with the music. You see, he was mostly facing the orchestra, and naturally could not see what the artists right at the other end of the studio were doing.

I noticed a small flashlight bulb at the side of the studio, operated from the producer's gallery above and behind me. Owing to the crowd of people in the studio, however, someone had to stand between the light and Mr. Coates and repeat the signal to him. In the same way, someone else stood at the far end of the studio in front of the artists, beating time to the music, with one eye on Mr. Coates and the other on the artists. Thus for the best part of the performance there were two conductors.

The "action" was going on at the far end of the studio, where the three Marconi-E.M.I. Emitron cameras were trained upon two scenes arranged at right-angles to each other. For "Mr. Pickwick" a revolving stage was also devised, and altogether it was possible to present four distinct scenes—Mrs. Bardell's Parlour, Courtyard and Interior of the Inn, and the Fleet Prison.

The general rehearsal procedure appeared to be that the players went through the performance bit by bit while Dallas Bower examined the

effectiveness of the setting and appearance on the screen in the control gallery. His voice filled the studio every few seconds, for it was reproduced by a loudspeaker just above my head. Most of his instructions were to Peter Bax, the stage manager, who answered back via the artists' microphone, which projected on a long movable arm to a position a few feet above the actors' heads.

"Move the table three inches up stage," shouted Mr. Bower. And this was done.

"Keep closer to the table, Mr. Pickwick," bellowed the voice again.

"Mark the position of that chair."

These and similar remarks went on all the time, and at length I began to realise that a producer's job at Ally Pally is no sinecure, but one which demands not only the necessary experience and skill, but nerves of steel.

When the positions of everything in each shot, animate and inanimate, had been determined and duly marked, the players went through a complete rehearsal.

Peter began the proceedings by blowing his whistle, which to me had a slightly humorous aspect. Everybody present immediately was frozen into statuesque silence. We all looked up at the indicator on the wall, which was flashing the words: "Vision On," "Sound On."

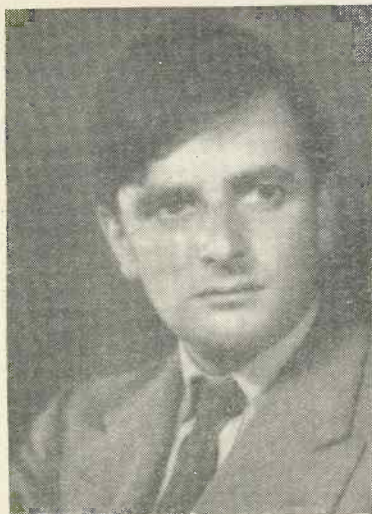

Stephen Thomas.



Dallas Bower.



Ben Lyon.

Last month, on pages 639 and 640, we inadvertently appended incorrect descriptions to two photographs which appeared on those pages. The first photograph, which was of Mr. Stephen Thomas, was described as being that of Mr. Dallas Bower, and the second one, which was stated to be Stephen Thomas, was actually a photograph of Ben Lyon. Stephen Thomas and Dallas Bower are, of course B.B.C. producers at Alexandra Palace, whereas Ben Lyon featured in the November 3rd programme with Bebe Daniels. Our sincere apologies are offered to the gentlemen concerned.

TELEVISION AND CINEMA COMPARISONS

This was the first time that stage scenery was used. One of the painted backcloths, which was supported from the ceiling on a long rafter of wood, was furled up and hoisted out of sight with the celerity of a sailing ship crew. Then another one slid down from the heavens in an equally efficient manner, and meantime the cameras were shooting the players at right-angles to the scenery that was being changed. The new scene was in position and ready in the nick of time.

And so this rehearsal went on, everything happening in a wonderfully clever way which made me just stand entranced and marvel at it all.

The person who I admired most of all was Peter Bax. He was the link between producer Dallas Bower up above, and the performers and assistants on the stage. Questions and instructions were shot at him with machine-gun-like rapidity, and on each occasion this very patient man did precisely as he was told, and walked quietly to the suspended microphone to reply to anything that Mr. Dallas Bower had asked. I came away with the settled impression that whatever salary a television stage manager gets, the job is worth double!

Among the distinguished cast in the television version of "Mr. Pickwick" must be mentioned William Parsons (Pickwick) and Dennis Noble (Mr. Weller).

* * *

Rosalind Wade's first appearance in the new programmes was notable for dancing fans. Miss Wade controls a large organisation which supplies dancing troupes all over Europe, and she is known colloquially as "Britain's Ziegfeld." One of her star troupes, known as "Rosalind Wade's Dancing Daughters," appeared weekly in the aural broadcast programmes for a long period. She was televised by the 30-line system.

Miss Wade's programme at the beginning of November was a demonstration of three different rhythms in tap dancing, incorporating (1) the Soft Shoe (which used to be known as the Schottische), (2) Rhythm and Swing, and (3) Buck and Wing.

* * *

Where television scores over ordinary broadcasting has been repeatedly demonstrated during the month, for it is surprising how many topical

events and news items require the visual element for their proper portrayal. For instance, viewers saw a fine display of Champion Alsations, which were brought from the Metropolitan and Essex Canine Society's show, while gardeners who possess a television receiver will have been delighted with the sight they got of the prize blooms brought from the National Chrysanthemum Society's show.

An attempt was also made to televise a "pre-view" of pictures and sculpture from various forthcoming exhibitions, but there are colour problems yet to solve in this connection.

* * *

One of the month's television performers who can fairly claim to have made a big hit is Arthur Prince, the ventriloquist, and his intelligent doll Jim. I think the television screen is particularly kind to a ventriloquist, because the definition is not sufficiently perfect to enable any very slight movement of the lips to be seen, although no one could detect Arthur Prince's lips moving anyhow.

The principal movie-people televised during the month were Bebe Daniels and Ben Lyon, the well-known Hollywood stars, who acted a

sketch which was quite funny, and sang in a charming manner.

* * *

One or two people have expressed the opinion to me that they did not think it wise for the B.B.C. to have too many people on the television screen who also were frequently seen on the cinema screen: it is no novelty.

But I do not think this criticism is sound. There is a difference between seeing even such a well known favourite as Bebe Daniels on the television screen and seeing her at the cinema, although I must confess the difference is more psychological than factual. You get that feeling when you see them at the cinema that it is a mechanical reproduction and definitely not real, but when you see them on the television screen, especially in close-ups, and you notice all those little peculiarities and mannerisms which are largely eliminated in the final version of any film, you perceive and enjoy a really intimate acquaintance with the characters which I personally have never felt when looking at a cinema screen.

The biggest success in the month's programmes, however, was Henry Hall, who looks like becoming as universal a favourite on the television screen as he is in aural broadcasting. His television performance with the B.B.C. Dance Orchestra was exceedingly good, and proved that Henry is as great a showman as a musician. Dan Donovan, the vocalist, deserves a word of congratulation for the notable part he played in making the band's television appearance such a huge success.

The general criticism of the month's television programmes seems to be that the fare offered to televiewers has been rather dull if considered from the entertainment angle. Leonard Henry, the well-known radio comedian, who was featured in "Starlight" in the middle of the month, when he did a gas-mask act, proved to be one of the liveliest items, but there is room for a general brightening up.

I mentioned this opinion to several officials at Alexandra Palace during my visits there and was assured that, in the programmes scheduled for the early future, this matter already has been given careful attention, and that a much better balance of different types of programme material may be expected.



Laurie Devine, the "Television Ballerina," one of the old favourites shortly to reappear on the television screen.

RECENT TELEVISION DEVELOPMENTS

A RECORD OF PATENTS AND PROGRESS *Specially Compiled for this Journal*

Patentees :—Marconi's Wireless Telegraph Co. Ltd., H. M. Dowsett and R. Cadzow
F. S. Turner :: Telfunken Ges für drahtlose Telegraphie :: Marconi's Wireless Telegraph
Co. Ltd., and A. A. Linsell.

Electron Multipliers (Patent No. 451,724.)

Self-sustained oscillations are produced in a tube containing two cathodes K, K₁ coated with highly-emissive substance, such as silver-caesium-hydride. A ring-anode A is placed midway between the two cathodes, and a strong magnetic field is directed along the axis of the tube by an external magnet N, S.

Electrons set free, say, from the cathode K, are attracted towards the positive anode A, and the resulting current automatically produces a

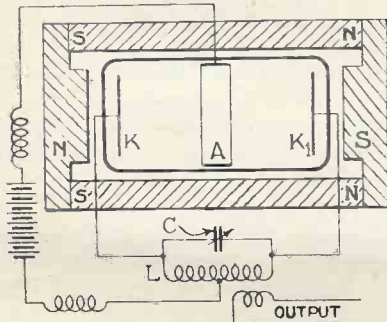

Electron Multiplier. Patent No. 451,724

voltage in the coil L of the tuned circuit L, C. This accelerates the electrons so that they reach the opposite cathode K₁ with sufficient speed to produce secondary emission there. The electrons so liberated are attracted back, in turn, towards the first cathode K, where they again set free fresh electrons. The process is repeated indefinitely, until the oscillations in the circuit L, C build up to the full capacity of the tube. The field from the magnet NS helps to focus and sweep the electrons through the ring-anode A.—Farnsworth Television Inc.

Cathode-Ray Screens (Patent No. 452,368.)

The ordinary fluorescent screen is replaced by a thin sheet, M, of metal which is separately heated from

a battery B, as shown, from one side of the tube. The pre-heating is such that the screen just fails to glow, but the impact of the electron stream from the cathode C of the tube, is sufficient to raise it to incandescence and thus reproduce the picture in visible form. Only the edge of the metal screen M is shown in the pic-

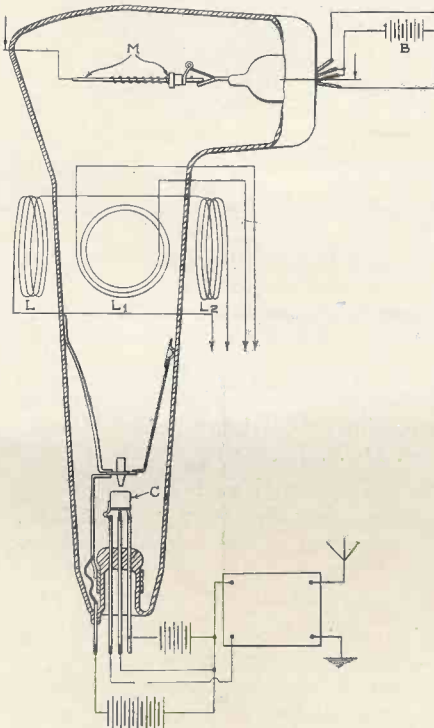

Cathode-ray tube for projection. Patent No. 452,368

ture, as the flat part faces towards the source of the electron stream. The usual scanning voltages are applied to deflecting coils L, L₁, L₂. The intensity of the image produced by incandescence is sufficient to allow the use of magnifying lenses, which project the picture on to a much larger viewing-screen situated outside the glass bulb.—F. S. Turner.

Our Policy
"The Development of
Television."

Television Receivers (Patent No. 452,148.)

One of the most expensive items in a television receiver is the cathode-ray tube, the cost of which increases with its size. The figure shows how a spherical mirror can be used in combination with a comparatively small tube to produce a clear picture 18 in. square.

The cathode tube T is inserted through an opening in the centre of the mirror R so that the latter faces

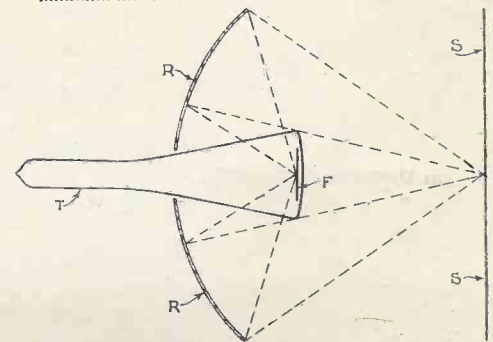

Combination of mirror and cathode-ray tube for projection. Patent 452,148.

the active side of the fluorescent screen F. As each scanning spot is formed, the light from it is picked up from all parts of the surface of the mirror, and reflected back on to a single point on the viewing screen S. In this way the mirror makes the best possible use of the limited fluorescent light available, and produces an enlarged picture of high definition.—Marconi's Wireless Telegraph Co., Ltd.; H. M. Dowsett; and R. Cadzow.

Enlarging the Picture (Patent No. 453,043.)

In order to throw a magnified image of the received picture on to an external viewing screen, the bulb end of the cathode-ray tube receiver is formed as a plano-concave lens. The fluorescent material is coated over the plane surface of the lens, and a simple

objective glass is then all that is required to project the televised picture, corrected for field-curvature, on to the final viewing screen.—*Telefunken Ges für drahtlose Telegraphie.*

A Super-regenerative Receiver

(Patent No. 453,135.)

The super-regenerative circuit is highly sensitive, and although its selectivity is not very critical, this is of small importance when working on the ultra-short wave-band, where there is little congestion.

The figure shows an arrangement in which two super-regenerative

the cathode-ray tube are connected to the time-base circuit which produces the synchronising or scanning voltages, but by depressing a push-button switch, this connection is broken and the deflecting plates are thrown across a resistance in the plate circuit of the first detector valve of the superhet circuit used to handle the sound part of the programme. The voltage developed across this resistance varies with strength of the carrier-wave, and the corresponding deflection of the electron stream in the cathode-ray tube shows when the circuits are accurately in tune with the

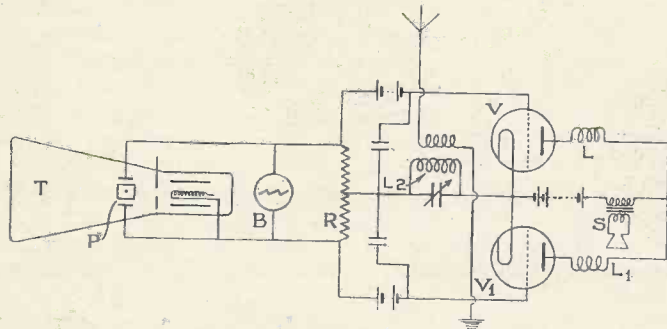

Circuit of super-regenerative receiver for television. Patent No. 453,135

valves are used for receiving the sound programme, the necessary "quenching" oscillations being conveniently derived from one of the scanning-frequencies used for the cathode-ray tube T which handles the picture signals. The two plate coils L, L1 of the push-pull valves V, V1 are back-coupled to the common input coil L2, so as to bring the valves to the verge of self-oscillation. The quenching frequency which prevents the valves from "boiling over" is applied to the grids from a resistance R shunted across the time-base circuit, shown diagrammatically at B. This is, of course, a necessary part of the equipment of the cathode-ray tube receiver T, and is used primarily to supply synchronising voltages to the deflecting plates P. Sound signals are reproduced in the loud speaker S, whilst the picture is seen on the fluorescent screen of the tube T.—*Marconi's Wireless Telegraph Co., Ltd., and A. A. Linsell.*

Tuning Indicators for Television Sets

(Patent No. 453,499.)

The cathode-ray tube used for reproducing the picture in a combined sound-and-television set serves also to indicate when the circuits of the receiver are accurately in tune.

Normally the deflecting-plates of

incoming signal.—*Marconi's Wireless Telegraph Co., Ltd., and A. A. Linsell.*

Summary of Other Television Patents

(Patent No. 447,046.)

Modulating television signals on an ultra-short carrier wave.—(*Radio Akt. D. S. Loewe.*)

(Patent No. 447,070.)

Preventing the cross-current from the electron stream to the deflecting electrodes of a cathode-ray tube.—(*Radio Akt. D. S. Loewe.*)

(Patent No. 438,905.)

Interleaved scanning-system for a film which has been specially prepared by compressing the picture detail in the direction of motion of the film.—(*C. O. Browne.*)

(Patent No. 440,087.)

Electron-optical arrangement of electrodes for focusing the stream in a cathode-ray tube.—(*Fernseh Akt.*)

(Patent No. 451,745.)

Electrode arrangement in a cathode-ray tube used for interleaved scanning.—(*Radio-Akt. D. S. Loewe.*)

Read

Television and Short-wave World

Regularly

(Patent No. 452,650.)

Producing clear-cut images in a cathode-ray tube utilising electrostatic deflection-control.—(*Radio-Akt. D. S. Loewe.*)

(Patent No. 452,715.)

Preventing reaction effects in a short-wave television receiver of the super-het type.—(*Radio-Akt. D. S. Loewe.*)

(Patent No. 452,844.)

Focusing the electron stream prior to the point where it is deflected by the scanning plates in a cathode-ray tube.—(*Radio-Akt. D. S. Loewe.*)

(Patent No. 453,223.)

Arrangements for focusing the electron stream in a cathode-ray tube.—(*Radio-Akt. D. S. Loewe.*)

(Patent No. 453,462.)

System for distributing television programmes to a number of stations linked together by a telephone line.—(*Electrical Research Products, Inc.*)

(Patent No. 453,496.)

Arrangement of electrodes and their mounting in a cathode-ray tube television receiver.—(*General Electric Co., Ltd., and G. W. Seager.*)

(Patent No. 454,256.)

Direction-finding system in which the bearings of a ship from a distant beacon station are indicated by television signals.—(*Marconi's Wireless Telegraph Co., Ltd.; R. J. Kemp; and D. L. Plaistowe.*)

(Patent No. 454,258.)

Electron "gun" construction for a cathode-ray tube.—(*Marconi's Wireless Telegraph Co., Ltd.; G. M. Wright; and G. F. Brett.*)

(Patent No. 453,886.)

Amplifier for handling television signals covering a wide band of frequencies.—(*Radio-Akt. D. S. Loewe.*)

"Televisor"

Messrs. Baird Television, Ltd., ask us to point out that the word "Televisor" is copyright and is used by the Baird Company as their trade mark. The word is so aptly descriptive of a television receiver that writers sometimes make the mistake of using it for any type of television receiver, whereas it is a coined word only applicable to Baird productions. In the Baird advertisement on page 623 of last month's issue a printer's error showed the word without inverted commas in the line—"Televisor" Receivers Mirror the World.

MERVYN SPECIFIED

FOR

'TELEVISION'S GUARANTEED'

CATHODE RAY RECEIVER

CONDENSERS.

8-mfd. 1,000v. working	18/6 each.
2-mfd. 1,000v. "	7/6 "
.25-mfd. 4,000v. "	9/- "
.1 Tubular 2,000v.	3/6 "
8 + 8-mfd. (for shift unit)	7/- "

4,000 volt unit complete, ready for use, smoothed output £4 10s.

A special built up control panel to Mervyn Standards cost only 48/-

VISION RECEIVER.

The radio section of a complete set proved on B.B.C. transmission. Ready for use, 8-BVA valves including power pack £16 10s.

FREE

A BLUEPRINT of a new reasonably priced amplified double time base, giving all values and detailed prices.

Send this coupon and 3d. in stamps for postage and despatch with your name and address.

All apparatus is obtainable through your dealer. In case of difficulty send your order direct to :—

THE MERVYN SOUND and VISION CO., LTD.

4, HOLBORN PLACE, LONDON, W.C.1

Telephone: HOLborn 7709

Managing Director : W. J. NOBBS, F.T.S., A.M.I.R.E.

You want the best condensers



have them!

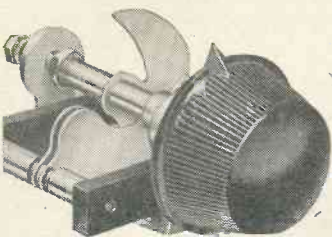

ULTRA SHORT-WAVE SINGLE
Capacities 15 mmf., 30 mmf., 00004, 0001, 00015
Price 3/9
With Slow-Motion Action 1/- extra.

ULTRA SHORT WAVE TWIN

Capacities 15 mmf., 30 m m f., 45 mmf.

Price 5/-
With Slow Motion Action 1/- extra

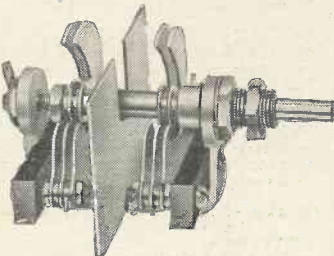

JACKSON BROTHERS (London) Ltd.
72, St. Thomas St., S.E.1. Telephone: Hop.1837.

CLIX

V1 - V2 - V4

Whatever the circuit or type of valve to be chosen, there is always a **CLIX** Valveholder to carry out its important duty to the entire satisfaction of the designer and constructor.

The three types illustrated are specified for the

"AMATEUR BANDS SUPER-HET 7"

You can rely upon Clix for long and faithful service.

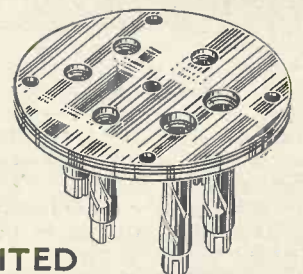
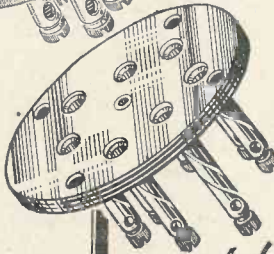
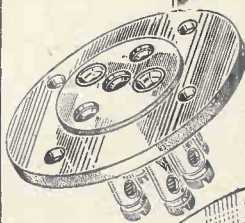

Send for our two latest Folders "T.S."

Yours faithfully

LECTRO LINX LIMITED

79^A ROCHESTER ROW. LONDON S.W.1

"The Amateur Bands Super-Het 7"

(Continued from page 715)

As the capacity of the wiring differs from chassis to chassis, it is necessary to readjust the B.F.O. to give the correct note. The adjusting screw for the B.F.O. is on the top of the metal container. With the set operating, tune in a station and turn on the B.F.O. If the oscillator is adjusted to the correct frequency, a beat note or high pitched whistle will be heard. If it is not adjusted correctly this can be attended to by means of the control knob on the top of the container. The pitch of the note can be varied by this adjustment to suit operators' individual tastes.

Those amateurs who have a signal generator capable of providing an accurate frequency of 456 kc., should adjust the receiver in the following way. Connect the output of the generator between chassis and the cap of the detector-oscillator valve. This will apply a signal to the grid of this valve which in no way upsets the adjustments of the I.F. circuit. The I.F. transformers can then be lined up to give maximum output on the valve voltmeter.

The bands covered by this receiver are extremely small and generally the calibration of an ordinary amateur signal generator is not sufficiently accurate to allow wavelength calibration of the tuning range of the receiver. Alignment may be made on band four, however, as previously described, by connecting the output of the signal generator to chassis and through a .0002-mfd. condenser to the aerial terminal of the receiver. With bands one, two and three, however, a non-inductive resistance of 400 ohms should be used instead of the .0002-mfd. condenser.

Due to variations in the wiring, as well as possible variations in the B.F.O. valve, harmonics may be noticeable. In such circumstances the cathode lead to the earthy end of the grid coil should be broken and a 1,000-ohm resistance inserted, so biasing the B.F.O. valve, and reducing the output.

An All-wave Model

The 35H tuner used in this circuit must be clearly understood to be suitable for the 20, 40, 80 and 160-metre amateur bands. Constructors needing an all-wave receiver of a conventional type should substitute for the 35H tuner a type 35. This tuner is absolutely interchangeable without any alteration, so that the same remarks apply to the users of a 35 tuner as to the 35H tuner. The band coverage, however, on the 35 tuner is 1.5 to .55 mc., 3.8 to 1.5 mc., 9 to 3.5 mc., and 22 to 9 mc.

With this tuner, a simple form of band-spreading is obtained owing to the use of a separate dial and pointer. Users of the 35 tuner who will probably not be interested in morse code reception, can omit the beat-frequency oscillator, so reducing the number of valves

and the total cost.

A phone jack has been incorporated in the resistance coupled stage between the detector and pentode output valve. This is a very necessary feature for real DX reception, although the impression must not be gained that the receiver is unsuited to loudspeaker reception. Generally speaking, there is no need for a phone jack, but amateurs interested in reception of weak C.W. stations will find the phone jack of great use.

The receiver will bring in amateur and commercial stations at very great strength, and owing to a specially designed A.V.C. action, signals that would

otherwise fade are kept at a reasonable level.

The controls on the front panel from left to right are as follows: High-frequency gain control, low-frequency gain control, stand-by switch, then a switch for A.V.C., main switch, beat note switch, phone jack and continuously variable tone corrector.

With the mains transformer it will be noticed that the centre tap of the filament and high-voltage windings are automatically connected to the chassis of the transformer by the makers. This means that there are two less wires to

(Concluded on page 736)



Old-fashioned reproduction may not be actively objectionable, but its insidious habit of sapping the life from a good programme can, unnoticed, rob you of the enthusiastic enjoyment radio should provide.

Radio as it should be—radio as it can be—radio as heard through the 1937 Stentorian—gives a degree of sparkling entertainment that will make you look forward to the evening programmes. Ask your dealer about this—the greatest single step forward in commercial reproducers ever made. He will gladly demonstrate—to-day!



See how little this realism costs:—

Chassis Models
37S ... 42/- 37B ... 23/6
37J ... 22/6 37M ... 17/6
Cabinet models from 29/6

Models from 39/6, or hire purchase terms from

7/6
down



1937 STENTORIAN
The *NEW* speaker with the *NEW* realism

WHITELEY ELECTRICAL RAD'O CO., LTD., (Vision Dept.), MANSFIELD, NOTTS.

can be taken out of circuit when the valve voltmeter is not in use. This prevents a continuous drain from the grid bias cell.

In series with the grid input lead is a 1-mfd. blocking condenser, its object being to prevent any D.C. voltage accidentally being applied to the grid of the valve.

A dial light is rather a luxury, but I have found it necessary to prevent the meter being left on when not in use.

Once the meter has been adjusted there is no need to make any further alterations. Decide upon the loudest signal one is likely to hear and adjust the H.T. supply so that this signal causes a full-scale deflection of 1 ma. This is done by a combination adjustment of H.T. and bias voltage. Bias voltage, of course, is easily varied by means of the 50,000-ohm potentiometer.

If an A.C. voltmeter is obtainable or can be loaned it is an excellent plan accurately to calibrate the valve voltmeter in volts input.

Connect a potentiometer across the filament winding of a mains transformer giving 4 volts, or if a higher voltage is used connect two filament windings in series. Join an A.C. voltmeter across the sliding arm of the potentiometer and to one side of the filament winding and check to see that the voltage is exactly 4 or 8 as the case may be. Then apply this voltage to the input circuit of the valve voltmeter and notice the amount of deflection obtained.

By varying the voltage from the transformer which is checked by the A.C. meter and then transferring it to the valve voltmeter, the latter instrument can be accurately calibrated in input volts. This enables the operator to give any transmitting station a most useful report on signal strength.

In no circumstances should H.T. or L.T. be obtained from the supply mains, for it is most difficult to eliminate all traces of hum. This will cause slight ripple in the reading and make the meter inaccurate on low inputs.

Constructors who need a more sensitive instrument for the checking of long-distance stations can substitute a screen grid valve for the triode, making sure to obtain the correct screen voltage by means of a variable potentiometer.

Eddystone Welded Steel Cabinets

Owing to the demand for steel cabinets as used in the Amateur Communication receiver described in the November issue, Messrs. Stratton & Co., Ltd., makers of Eddystone steel cabinet is 17 in. wide, 9½ in. deep and large type 1034 cabinet to 18s. 6d. This cabinet is 17 in. wide, 9½ in. deep and 9½ in. high, complete with hinged lid, so it is really excellent value for money. A smaller cabinet, type 1033, size 8½ in. wide, by 9½ in. deep by 9½ in. high is priced at 12s. 6d.

GALPINS

ELECTRICAL STORES

75, LEE HIGH ROAD,
LEWISHAM, LONDON, S.E.13

TELE. : LEE GREEN 5240

Cash with Order or C.O.D.

TWO-INCH SPARK COIL, complete in case, with all fittings, 17/6; one-inch spark coil in case, with condenser, but no contact breaker, 2/6. Post 6d.

TRANSMITTING VARIABLE CONDENSERS, .0005 m. glass case type, 12/6.

FLUORESCENT SCREEN, 17 x 14 in., framed, as new and complete with protected mounting frame, £3 10s. C/F.

X-RAY TUBES, new condition, with Tungsten Target, 15/-; with Platinum Target, 20/- C/F. Packing free.

UNIVERSAL MOTORS, A.C. or D.C., approx. ¼ h.p., 200/250 v. for baby cines, television, or any small power work, 10/6. Post 6d.

MORSE PRACTICE SET, complete on wood base; heavy brass G.P.O. morse key, complete with contacts; high class buzzer and 4½ volt battery, in complete working order. Not a toy, but a serious practice set, ready for immediate use, price 3/- Post 6d.

EX-R.A.F. MORSE KEYS, fully adjustable, price 2/6. Post 6d.

WESTERN ELECTRIC MICROPHONES, solid back type, very sensitive, 2/6 each.

MICROPHONE TRANSFORMERS, high ratio, finest quality, 2/6 each.

ELECTRIC LIGHT CHECK METERS, Maker "Ferranti," 1 kilowatt-hour type, 200/250 v. single phase, 50 cycle for subletting, etc., 6/- each. Post 1/-.

MULTIPLE SWITCH, with sensitive actuating Relay, as new, ex. automatic Phones, 4/6 each.

DYNAMOS for Lighting or Charging, all shunt wound, fully guaranteed. 150 v. 1 a., 17/6; 100 v. 3 a., compound, 30/-; 200 v. 3 a., compound 50/-; 20 v. 5 a., compound, 30/-; Aero dynamos, 12 v. 8 a., 10/-, all C/F.

CHARGING RESISTANCES or Shunt Regulators. Stud, switcharm type, 12/6 each, to suit your requirements.

C.A.V. AUTOMATIC CHARGING CUT-OUTS, suit any voltage, 7/6 each.

ISENTHAL VARIABLE RESISTANCE, to carry 10 to 15 amps., fitted 0 to 15 a/meter and Pilot Lamp, as new, 17/- C/F.

G.P.O. GLASS TOP RELAYS, Type B, highly sensitive, 7/6 each.

DUPEX TELEGRAPH MORSE KEYS, send-and-receive type, 12/6.

G.P.O. GALVANOMETERS, in vertical polished mahogany case, 5/- each. Post 9d.

BRIDGE TYPE CALVS., horizontal type, super sensitive, fully calibrated scale, price 7/6. Post 6d.

BELLING ELECTRIC FIRES, 200/250 volts 2 kW., 2- or 3-bar type, in good condition, 15/- C/F.

EXIDE, 2-volt, 30/60 a.h. unspillable Accumulators, type 3PZ3. Guaranteed sound. 2/6 each. Post 1/-.

MOVING COIL METER Movements for recalibrating into multirange meters, 5/6 each.

"WESTON" & TURNER 2½ in. Dial Moving Coil Milliamps Meters, 250 m/A, 12/6; 3½ in. dial, 0 to 500 m/A, 15/- Thermo Ampmeters, 0 to 1½ a., 0 to 12 a., 15/-; 2½ in. dial. All as new.

FILAMENT TRANSFORMERS, 220 v. input, 20 v. 32 amps. out, 35/- C/F. H.T. Smoothing Choke, 25/-.

DIMMER SWITCH for 12 volt control, suitable for regulating electric trams, 12 v. lighting, etc., 2/6 each.

R.A.F. CHARGING CUT-OUTS also fitted voltage regulators, fully adjustable, suitable for 12 to 20 volt charging dynamos, price 2/- Post 6d.

EX-R.A.F. SEARCHLIGHT, 12 in. dia. beam arc type, as new, power 2 kW., £5. C/F.

MAINS CHOKES, 20 and 30 hy., 40, 60, 80 m/A, 1/3, 1/9 and 2/6 each. Microphone Buttons, 9d. each. Automatic Telephone Dials, 2/6 each.

Cartridge Type Resistances, 600, 5,000, 10,000, 20,000, 50,000 ohms, 9d. each. W/E 1,000 single Earphones, 1/3 each. H/and, 9d. each. T.C.C. 2 mf. Condensers, 250 v. working, 9d. each. Mains Power Packs, 2 x 2 mfs., 2 x 20 hy. Chokes, 3/-.

BIRMINGHAM RADIMART SHORT-WAVE SPECIALISTS

We have pleasure in announcing that the 1936-7 Editions of the

RAYMART

MANUAL & CATALOGUE
are now ready for distribution.



CATALOGUE FOR 1937

Enlarged to three times its previous size and now the largest and most comprehensive wholly Shortwave Catalogue published but still only 1½d. Post free.

SHORT-WAVE MANUAL (48 PAGES)

RAYMART SHORT-WAVE MANUAL contains 48 Pages of practical circuits and data on Shortwave Receivers, transmitters, modulators; transceivers, etc., including information on transmitting licences, "class B" modulation, aerials, etc. Price with Catalogue 6d. or 7½d. post free.

RAYMART SPECIFIED IN THIS ISSUE.
TOBE TUNER Amateur Bands. Complete with amateur band-spread dial, £6 10

OSCILLATOR, beat frequency. Type B.F.O. Price 10/6.

COILFORM 7-pin (unwound) machine threaded to fit 7-pin valveholder. Type CT7, 2/-.

STAND-OFF INSULATORS. Glazed insulators with nickel-plated terminals. Type ST., 3d. each.

RADIMART (G5NI)

44, Holloway Head, Birmingham, I. Tel. : MID. 3254

Book Review.

"Television with Cathode-Rays"
(Pacific Radio Publishing Co., Inc., San Francisco, Calif.)

The operating principles of the cathode-ray tube and its application to television are explained in terms which can be understood by amateurs.

The main treatment starts with the practical use of the cathode-ray tube as a voltmeter. The fundamental theory of electrostatic effects, including capacitive reactance, of electromagnetic and high-frequency resistance effects including inductive reactance.

The concept of radiation is then developed from the electron theory and applied to the formation of optical images. This is the basis for an account of the action of electron lenses and of photo-electric and fluorescent effects as applied in television. The discussion is confined to the systems developed by Zworykin and by Farnsworth. The price is \$2.75.

TELEVISION DEVELOPMENTS

A NEW LARGE DIAMETER TUBE FOR TELEVISION REPRODUCTION

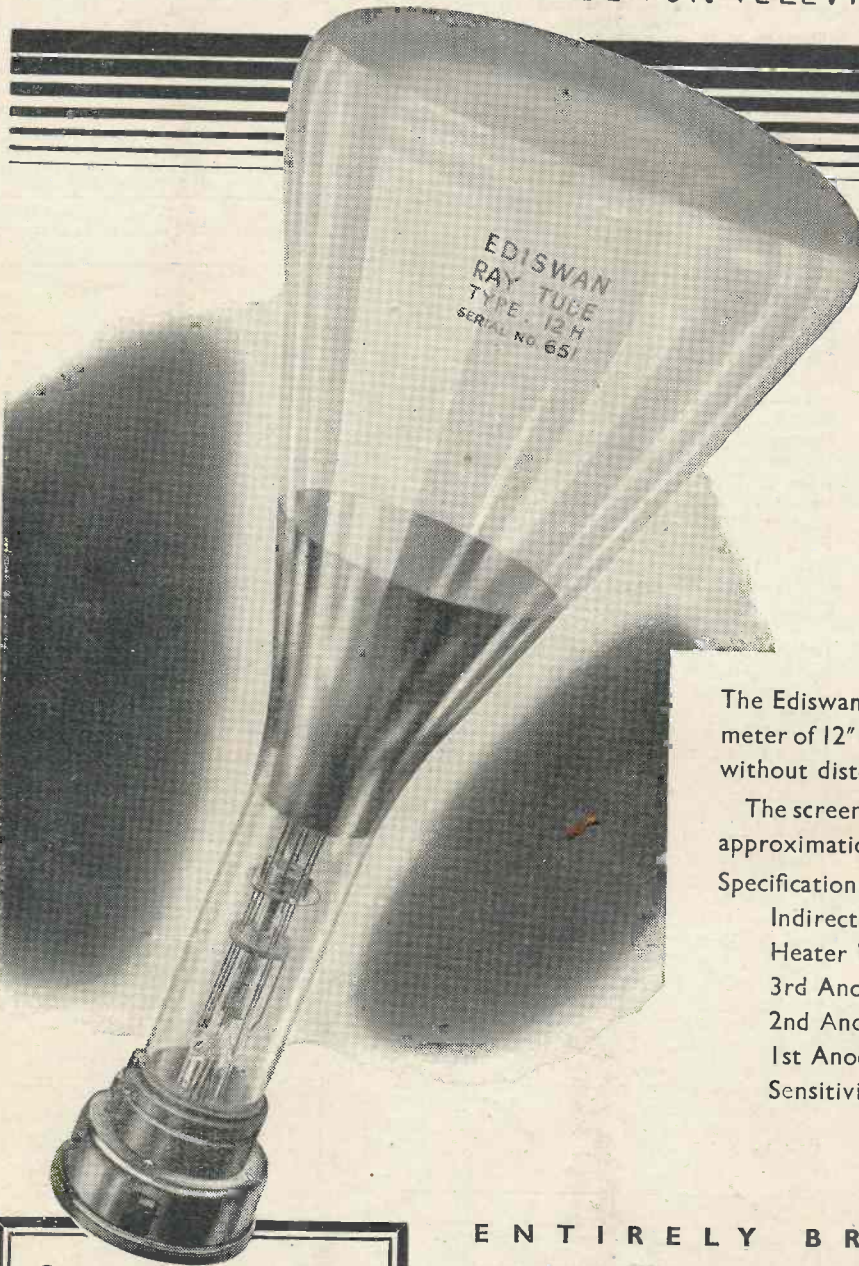

**TYPE 12H
TUBE**

The Ediswan Type 12H tube has a screen diameter of 12" giving a television picture 10" x 7½" without distortion.

The screen is of special material giving a close approximation to a black-and-white picture.

Specification:

Indirectly heated high vacuum tube.			
Heater Volts	-	-	2.0
3rd Anode Volts	-	-	6000
2nd Anode Volts	-	-	1200
1st Anode Volts	-	-	150-400
Sensitivity (mm./V.)	-	-	-950/V*

*V = anode volts

List Price £15. 15. 0

● We also supply
HIGH VACUUM RECTIFIERS
GAS-FILLED RELAYS
MERCURY VAPOUR RELAYS
for Television Scanning
circuits.

ENTIRELY BRITISH MADE

EDISWAN RADIO VALVES

THE EDISON SWAN ELECTRIC CO. LTD.  155 CHARING CROSS RD., LONDON, W.C.2

R.E. 299

USED BY ALL GOVERNMENT DEPARTMENTS

Printed in Great Britain for the Proprietors and Publishers, BERNARD JONES PUBLICATIONS, LTD., Chancery House, Chancery Lane, London, W.C.2, by THE PRESS AT COOMERLANDS LTD., Addlestone, Surrey. Sole Agents for South Africa: CENTRAL NEWS AGENCY, LTD. Sole Agents for Australia and New Zealand: GORDON AND GOTCH (AUSTRALASIA), LTD.